

FAGOR AUTOMATION S.COOP.

**Brushless AC
Servo Drives
~ ACSD series ~**

Ref.1609



FAGOR AUTOMATION



14460063

Original instructions

Title	Brushless AC Servo Drives. ACSD series.
Type of documentation	Description, installation and startup of motors and digital drives.
Name	MAN REGUL ACSD (IN)
Reference	Ref.1609
Software	Version 02.04 and earlier versions
WinDDSSetup	Version 08.15
Electronic document	man_acsd. pdf
Headquarters	FAGOR AUTOMATION S.COOP. B.º San Andrés 19, Apdo. 144 E- 20500 ARRASATE- MONDRAGÓN www.fagorautomation.com info@fagorautomation.es



34-943-719200



34-943-771118 (Technical Support)

The information described in this manual may be subject to changes due to technical modifications. FAGOR AUTOMATION, S. Coop. reserves the right to change the contents of this manual without prior notice.

The contents of this manual have been verified and matched with the product described here. Even so, it may contain involuntary errors that make it impossible to ensure an absolute match. However, the contents of this document are regularly checked and updated implementing the necessary corrections in a later edition.

All rights reserved. No part of this documentation may be copied, transmitted, transcribed, stored in a backup device or translated into another language without Fagor Automation's permission.

DUAL-USE products.

Products manufactured by Fagor Automation S. Coop. included on the list of dual-use products according to regulation (UE) Nr 1382/2014. Their product identification includes the text **-MDU** and require an export license depending on destination.

WARRANTY CONDITIONS

FAGOR AUTOMATION guarantees its products for the period of time with the exceptions indicated below, against defects in design, materials used and manufacturing process that affect the correct operation of the product.

The warranty period will have an initial duration of 24 months, applicable to all FAGOR products from the date the material is shipped to the customer. The manufacturers (OEM) or distributors will have a maximum period of 12 months from the time the product leaves FAGOR AUTOMATION warehouse to register the warranty. If the manufacturer, distributor and/or end user registers or informs FAGOR AUTOMATION regarding the final destination, date of installation and identification of the machine through any of the methods described by FAGOR AUTOMATION Product Warranty registration process, this warranty will commence for 24 months period from the date of registration, with a maximum limit of 36 months from the time the product leaves the facilities of FAGOR AUTOMATION; i.e., the period between the product shipping date and the date the warranty ends must not exceed a total of 36 months.

If a product has never been registered, the warranty period will end 24 months from the time the product leaves FAGOR AUTOMATION's warehouses. After this period, a warranty extension contract, for the material, must be executed or a specific agreement reached with FAGOR AUTOMATION.

In the case of new replacement parts, the applicable warranty will be 12 months. With repaired products or in those cases where the product exchange option was used, during outside product warranty period-the applicable warranty will be provided by the corresponding repair center. When a repair estimate is provided it pertains to a specific defective item/s hence the warranty only covers the replaced part.

FAGOR guarantees to provide service for all current products and until 8 years after the date they are removed from the current catalog including repair, providing replacement part service or replacing the product with another identical or equivalent model. A backward compatible solution is available for most products i.e. the product can be upgraded to a newer model.

It is entirely up to FAGOR to determine whether the repair is to be considered under warranty.

During the warranty period, and following identification and diagnosis, FAGOR AUTOMATION will only repair or replace the product/part assessed to be defective. FAGOR AUTOMATION is not liable for any other compensation.

FAGOR AUTOMATION at its sole discretion reserves the right either to repair or replace the affected product during warranty period.

This product warranty covers all costs of materials and labor to repair or correct the cause of defect. The repairs will be carried out at the facilities of FAGOR AUTOMATION, unless it is agreed between FAGOR AUTOMATION and the CUSTOMER to carry out the repairs on the premises of the CUSTOMER or end user. Unless there is a specific agreement in cases of onsite repair all expenses related to diagnosis, labor, travel expenses, shipping costs, etc. are excluded and will be billed according to FAGOR AUTOMATION's established rate. The customer/user will be notified in advance of the estimate of charges when applicable.

The part/s replaced under warranty will be a property of FAGOR AUTOMATION.

FAGOR AUTOMATION offers to its customers an extension to the standard warranty and comprehensive warranty services through SERVICE CONTRACTS that meet the diverse needs of customers.

Excluded from this warranty are:

- a) Deteriorated/Defective components as the result of mishandling, in violation of safety rules or the technical specifications of the product, inadequate monitoring or any type of negligence on behalf of the CUSTOMER.
- b) Defects caused by improper handling, assembly and/or installation by the CUSTOMER or caused by modifications or repairs carried out without the consent of FAGOR AUTOMATION.
- c) Defects caused due to specific materials, fluids/coolants, electricity power or services used by the CUSTOMER.
- d) The malfunctions caused by unforeseen circumstances or force majeure (weather or geological events) and accidents or any other type of natural disaster.
- e) In a general sense, any indirect, consequential and/or collateral damage.
- f) Damage caused during transport.

All service requests during the warranty period must be communicated to FAGOR AUTOMATION, identifying the product (serial number), describing in detail the symptoms observed, the reason for the malfunction (if known) and its scope.

All components replaced within the warranty period are covered by the warranty until the expiration of the original warranty period of the product.

The warranty offered by FAGOR AUTOMATION will become null and void in the event that the CUSTOMER fails to comply with the installation and operation requirements and recommendations regarding preventive and corrective maintenance as indicated in product manuals.

DECLARATION OF CONFORMITY

Manufacturer: Fagor Automation, S. Coop.

B.º San Andrés 19, C.P. 20500, Mondragón - Gipuzkoa - (SPAIN)

We hereby declare, under our responsibility that the product:

FAGOR AC BRUSHLESS SERVODRIVE SYSTEM

Parameter setting for the drive modules.

ACSD-05L, ACSD-10L, ACSD-20L, ACSD-30L

ACSD-04H, ACSD-08H, ACSD-16H

and feed axis servo motors:

FXM1, FXM3, FXM5, FXM7, FKM2, FKM4, FKM6

Note. Some additional characters may follow the model references indicated above. They all comply with the directives listed here. However, compliance may be verified on the label of the unit itself.

mentioned on this declaration, meet the requirements on:

Safety

EN 60204-1:2007

Machinery safety. Electrical equipment of the machines.

CORR:2010

Part 1: General requirements.

Electromagnetic Compatibility

EN 61800-3:2004

EMC directive on servo drive systems.

/A1:2012

In compliance with EC Directives 2014/35/UE on Low Voltage and 2014/30/UE on Electrical Compatibility.

Fagor Automation, S. Coop.



Director Gerente
José Pérez Berdud

In Mondragón September 1st 2016

INTRODUCTION

FAGOR offers you a wide range of servo drive systems (AC Brushless motor + Digital Drive) for applications requiring between 1.2 and 33.6 N·m at speeds between 1200 rev/min and 4000 rev/min for FXM motors and between 1.7 and 23.5 N·m at speeds between 2000 rev/min and 6000 rev/min for FKM motors.

This manual describes the elements in detail and guides step by step through the installation and setup of the drive system.

When installed for the first time, read the whole document.

Should you have any doubts or questions, please do not hesitate to contact our technicians at any of our subsidiaries worldwide.

Thank you for choosing FAGOR.

General index

BRUSHLESS AC MOTORS, FXM	7
Introduction	7
General characteristics	7
Dimensions	11
Power connector	13
Motor feedback connector.....	14
Holding brake	15
Sales reference	16
BRUSHLESS AC MOTORS, FKM	17
Introduction	17
General characteristics	17
Dimensions	20
Power connector	21
Motor feedback connector.....	22
Holding brake	23
Sales reference	24
COMPACT SERVO DRIVE, ACSD	25
Introduction	25
General characteristics	25
Dimensions	26
Technical data.....	26
Connectors.....	27
Indicators.....	28
Push-buttons and switches	29
Front panel and pinout of the connectors.....	30
Unit identification	32
Sales reference	32
INSTALLATION	33
General considerations	33
Electrical connections	34
Cables	40
CAN field bus connection.....	41
Codes of the FAGOR cables.....	42
Connecting a drive to a PC. RS-232 serial line.....	43
Diagram of the electrical cabinet.....	44
Initialization and adjustment.....	45
PARAMETERS, VARIABLES & COMMANDS	49
Notation.....	49
Groups	51
ERROR CODES	71
PARAMETERS, VARIABLES & COMMANDS. IDs.....	76

This page intentionally left blank

BRUSHLESS AC MOTORS, FXM

Introduction

FXM series synchronous servo motors are AC Brushless, with permanent magnets.

They are ideal for any application requiring great positioning accuracy. They have a uniform output torque, high reliability and low maintenance. They are designed to meet the IP 64 protection standard and, therefore, they are immune to liquid and dirt.

FXM1 FXM3 FXM5 FXM7

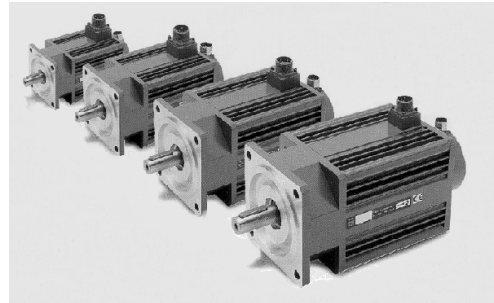

IP 64 means that it is protected against dust and against water jets. They incorporate a temperature sensor for monitoring the internal temperature. They also carry an optional electromechanical brake. The F class isolation on the motor maintains the dielectric properties as long as the work temperature stays below 150°C/302°F.

General characteristics

T. 6 FXM servomotors. General characteristics.

Excitation	Permanent rare earth magnets (SmCo)
Temperature sensor	PTC thermistor. Triple
Shaft end	Cylindrical with keyway (optional with no keyway)
Mounting	Face flange
Mounting method	IM B5 - IM V1 - IM V3 (as recommended by IEC-34-3-72)
Mechanical tolerances	Normal class (meets IEC-72/1971)
Balancing	Class N (R optional) (DIN 45665) whole-key balancing
Roller bearings' life	20000 hours
Noise	DIN 45635
Vibration resistance	Withstands 1g, along the shaft and 3g sideways ($g=9.81 \text{ m/s}^2$)
Electrical insulation	Class F (150°C/302°F)
Insulation resistance	500 V DC, 10 MΩ or greater
Dielectric rigidity	1500 V AC, one minute
Protection degree	General: Standard IP 64. Shaft: Standard IP 64, IP 65 with oil seal
Storage temperature	-20°C/+80°C (-4°F/+176°F)
Ambient temperature	0°C/+40°C (+32°F/+104°F)
Working ambient humidity	From 20% to 80% (non condensing)
Holding brake	Optional. See technical data ·holding brake·
Feedback	I0 Incremental TTL encoder ·2500 ppt· E1/A1 Sincoder encoder / SinCos multi-turn abs. encoder ·1024 ppv·
Meaning of the codes of the mounting method.	<p style="text-align: center;">IM B5 IM V1 IM V3</p>

T. 2 Technical data of non-ventilated synchronous FXM motors with “F” winding (220 V AC).

Non-ventilated motors	Stall torque	Stall peak torque	Rated speed	Stall current	Peak current	Calculation power	Torque constant	Acceleration time	Inductance per phase	Resistance per phase	Inertia ¹	Mass ²	Drive peak torque			
	Mo N·m	Mp N·m	nN rpm	Io A	I _{max} A	P _{cal} kW	kt N·m/A	tac ms	L mH	R Ω	J kg·cm ²	M kg	ACSD-05L N·m	ACSD-10L N·m	ACSD-20L N·m	ACSD-30L N·m
FXM11.40F.□□.□□□□	1.2	6	4000	2.0	10.0	0.5	0.6	8.4	12.0	4.60	1.2	3.3	3.0	6.0		
FXM12.40F.□□.□□□□	2.3	11	4000	3.9	18.7	1.0	0.6	7.2	5.5	1.45	1.9	4.3		6.0	11.0	
FXM13.40F.□□.□□□□	3.3	16	4000	5.6	27.2	1.4	0.6	6.8	3.5	0.80	2.6	6.4		12.0	16.0	
FXM14.20F.□□.□□□□	4.1	20	2000	3.5	17.1	0.9	1.2	3.5	10.0	2.30	3.3	7.6		12.0	20.0	
FXM14.40F.□□.□□□□	4.1	20	4000	6.9	33.7	1.7	0.6	6.9	2.6	0.55	3.3	7.6		12.0	18.0	
FXM31.20F.□□.□□□□	2.6	13	2000	2.2	11.0	0.5	1.2	5.6	24.0	5.05	3.5	5.5	6.0	12.0	13.0	
FXM31.40F.□□.□□□□	2.6	13	4000	4.4	22.0	1.1	0.6	11.3	6.1	1.25	3.5	5.5		6.0	12.0	13.0
FXM32.20F.□□.□□□□	5.1	25	2000	4.3	21.1	1.1	1.2	5.0	11.0	1.65	6.0	7.5		12.0	24.0	25.0
FXM32.40F.□□.□□□□	5.1	25	4000	8.4	41.2	2.1	0.6	10.0	2.9	0.44	6.0	7.5		12.0	18.0	18.0
FXM33.20F.□□.□□□□	7.3	36	2000	6.3	31.1	1.5	1.2	4.9	6.7	0.90	8.5	9.6		24.0	36.0	36.0
FXM33.40F.□□.□□□□	7.3	36	4000	12.0	59.2	3.1	0.6	9.9	1.8	0.25	8.5	9.6		24.0	18.0	18.0
FXM34.20F.□□.□□□□	9.3	46	2000	7.6	37.6	1.9	1.2	5.0	5.3	0.65	11.0	11.5		24.0	36.0	36.0
FXM34.40F.□□.□□□□	9.3	46	4000	15.0	74.2	3.9	0.6	10.0	1.3	0.17	11.0	11.5		24.0	18.0	18.0
FXM53.20F.□□.□□□□	11.9	59	2000	9.9	49.1	2.5	1.2	7.8	5.0	0.45	22.0	15.8		24.0	36.0	36.0
FXM53.30F.□□.□□□□	11.9	59	3000	14.8	73.0	3.7	0.8	11.7	2.2	0.20	22.0	15.8		24.0	24.0	24.0
FXM54.20F.□□.□□□□	14.8	74	2000	12.7	63.5	3.1	1.2	8.2	3.4	0.27	29.0	17.8		24.0	36.0	36.0
FXM55.12F.□□.□□□□	17.3	86	1200	9.1	45.2	2.2	1.9	5.3	7.2	0.55	36.0	20.0		38.0	57.0	57.0
FXM55.20F.□□.□□□□	17.3	86	2000	15.0	74.6	3.6	1.1	8.8	2.5	0.19	36.0	20.0		38.0	33.6	33.6
FXM73.12F.□□.□□□□	20.8	104	1200	10.7	53.5	2.6	1.9	7.4	9.8	0.60	61.0	29.0		38.0	57.0	57.0
FXM74.12F.□□.□□□□	27.3	135	1200	13.5	66.8	3.4	2.0	7.3	7.8	0.45	79.0	31.6		38.0	60.0	60.0
FXM75.12F.□□.□□□□	29.5	165	1200	15.0	83.9	3.7	2.0	7.4	5.9	0.31	97.0	36.0		38.0	60.0	60.0

1. When adding the mechanical brake to the motor (option) also take into account the inertia values given in the table of section ·holding brake characteristics ·.

2. When adding the mechanical brake to the motor (option) also take into account its mass values given in the table of section ·holding brake characteristics ·.

NOTE: In the combinations shown in bold letters, the drive will limit its peak current automatically so as not to damage the motor.

T. 3 Technical data of non-ventilated synchronous FXM motors with “A” winding (400 V AC).

Non-ventilated motors	Stall torque	Stall peak torque	Rated speed	Stall current	Peak current	Calculation power	Torque constant	Acceleration time	Inductance per phase	Resistance per phase	Inertia ¹	Mass ²	Drive peak torque		
	Mo N·m	Mp N·m	nN rpm	Io A	I _{max} A	P _{cal} kW	kt N·m/A	tac ms	L mH	R Ω	J kg·cm ²	M kg	ACSD-04H N·m	ACSD-08H N·m	ACSD-16H N·m
FXM11.20A.□□.□□□□	1.2	6	2000	0.45	2.2	0.3	2.7	4.2	248	93.5	1.2	3.3	6.0		
FXM11.30A.□□.□□□□	1.2	6	3000	0.67	3.4	0.4	1.8	6.3	110	43.0	1.2	3.3	6.0		
FXM11.40A.□□.□□□□	1.2	6	4000	0.90	4.5	0.5	1.3	8.4	62	23.5	1.2	3.3	5.2	6.0	
FXM12.20A.□□.□□□□	2.3	11	2000	0.86	4.1	0.5	2.7	3.6	111	32.0	1.9	4.3	10.7	11.0	
FXM12.30A.□□.□□□□	2.3	11	3000	1.29	6.2	0.7	1.8	5.4	49	13.0	1.9	4.3	7.1	11.0	
FXM12.40A.□□.□□□□	2.3	11	4000	1.72	8.2	1.0	1.3	7.2	28	7.8	1.9	4.3	5.4	10.7	11.0
FXM13.20A.□□.□□□□	3.3	16	2000	1.23	6.0	0.7	2.7	3.4	71	16.0	2.6	6.4	10.7	16.0	
FXM13.30A.□□.□□□□	3.3	16	3000	1.85	9.0	1.0	1.8	5.1	32	7.25	2.6	6.4	7.1	14.2	16.0
FXM13.40A.□□.□□□□	3.3	16	4000	2.50	12.0	1.4	1.3	6.8	18	4.05	2.6	6.4		10.6	16.0
FXM14.20A.□□.□□□□	4.1	20	2000	1.53	7.5	0.9	2.7	3.5	52	12.0	3.3	7.6	10.7	20.0	
FXM14.30A.□□.□□□□	4.1	20	3000	2.30	11.2	1.3	1.8	5.2	23	4.85	3.3	7.6		14.2	20.0
FXM14.40A.□□.□□□□	4.1	20	4000	3.10	15.0	1.7	1.3	6.9	13	2.95	3.3	7.6		10.6	20.0
FXM31.20A.□□.□□□□	2.6	13	2000	0.97	4.8	0.5	2.7	5.6	126	29.0	3.5	5.5	10.7	13.0	
FXM31.30A.□□.□□□□	2.6	13	3000	1.45	7.3	0.8	1.8	8.5	56	12.5	3.5	5.5	7.2	13.0	
FXM31.40A.□□.□□□□	2.6	13	4000	1.92	9.6	1.1	1.4	11.3	32	7.25	3.5	5.5	5.4	10.8	13.0
FXM32.20A.□□.□□□□	5.1	25	2000	1.89	9.2	1.1	2.7	5.0	56	9.55	6.0	7.5	10.8	21.6	25.0
FXM32.30A.□□.□□□□	5.1	25	3000	2.80	14.0	1.6	1.8	7.5	25	4.05	6.0	7.5		14.6	25.0
FXM32.40A.□□.□□□□	5.1	25	4000	3.80	18.5	2.1	1.4	10.1	14	2.3	6.0	7.5		10.7	21.4

1. When adding the mechanical brake to the motor (option) also take into account the inertia values given in the table of section ·holding brake characteristics·.
 2. When adding the mechanical brake to the motor (option) also take into account its mass values given in the table of section ·holding brake characteristics·.
- NOTE: In the combinations shown in bold letters, the drive will limit its peak current automatically so as not to damage the motor.

T. 4 Technical data of non-ventilated synchronous FXM motors with “A” winding (400 V AC).

Non-ventilated motors	Stall torque	Stall peak torque	Rated speed	Stall current	Peak current	Calculation power	Torque constant	Acceleration time	Inductance per phase	Resistance per phase	Inertia ¹	Mass ²	Drive peak torque		
													ACSD-04H	ACSD-08H	ACSD-16H
	Mo	Mp	nN	Io	Imax	Pcal	kt	tac	L	R	J	M	N·m	N·m	N·m
FXM33.20A.□□.□□□□	7.3	36	2000	2.7	13.4	1.5	2.7	4.9	36	5.05	8.5	9.6	21.6		36.0
FXM33.30A.□□.□□□□	7.3	36	3000	4.1	20.0	2.3	1.8	7.4	16	2.20	8.5	9.6	14.2		28.5
FXM33.40A.□□.□□□□	7.3	36	4000	5.5	27.0	3.1	1.3	9.9	8.6	1.15	8.5	9.6			21.3
FXM34.20A.□□.□□□□	9.3	46	2000	3.4	17.0	1.9	2.7	5.0	26	3.45	11.0	11.5	21.9		43.8
FXM34.30A.□□.□□□□	9.3	46	3000	5.1	25.0	2.9	1.8	7.5	12	1.60	11.0	11.5			29.1
FXM34.40A.□□.□□□□	9.3	46	4000	6.9	34.0	3.9	1.4	10.0	6.6	0.85	11.0	11.5			21.6
FXM53.12A.□□.□□□□	11.9	59	1200	2.8	14.0	1.5	4.2	4.7	61	5.85	22.0	15.8	34.0		59.0
FXM53.20A.□□.□□□□	11.9	59	2000	4.7	23.0	2.5	2.5	7.8	22	2.15	22.0	15.8			40.5
FXM53.30A.□□.□□□□	11.9	59	3000	7.1	35.0	3.7	1.7	11.7	9.6	0.91	22.0	15.8			26.9
FXM54.12A.□□.□□□□	14.8	74	1200	3.5	17.6	1.9	4.2	4.9	44	3.70	29.0	17.8	33.8		67.7
FXM54.20A.□□.□□□□	14.8	74	2000	5.9	30.0	3.1	2.5	8.2	16	1.35	29.0	17.8			40.2
FXM54.30A.□□.□□□□	14.8	74	3000	8.7	44.0	4.7	1.7	12.3	7.3	0.64	29.0	17.8			27.2
FXM55.12A.□□.□□□□	17.3	86	1200	4.1	20.0	2.2	4.2	5.3	36	2.95	36.0	20.0	33.8		67.5
FXM55.20A.□□.□□□□	17.3	86	2000	6.7	33.0	3.6	2.6	8.8	13	1.05	36.0	20.0			41.3
FXM73.12A.□□.□□□□	20.8	104	1200	4.9	25.0	2.6	4.2	7.4	46	3.05	61.0	29.0			67.8
FXM73.20A.□□.□□□□	20.8	104	2000	8.2	41.0	4.4	2.5	12.3	17	1.10	61.0	29.0			40.6
FXM74.12A.□□.□□□□	27.3	135	1200	6.6	32.0	3.4	4.2	7.4	33	1.90	79.0	31.6			66.2
FXM75.12A.□□.□□□□	33.6	165	1200	8.0	39.0	4.2	4.2	7.4	27	1.45	97.0	36.0			67.2

1. When adding the mechanical brake to the motor (option) also take into account the inertia values given in the table of section ·holding brake characteristics·.

2. When adding the mechanical brake to the motor (option) also take into account its mass values given in the table of section ·holding brake characteristics·.

NOTE. In the combinations shown in bold letters, the drive will limit its peak current automatically so as not to damage the motor.

Dimensions

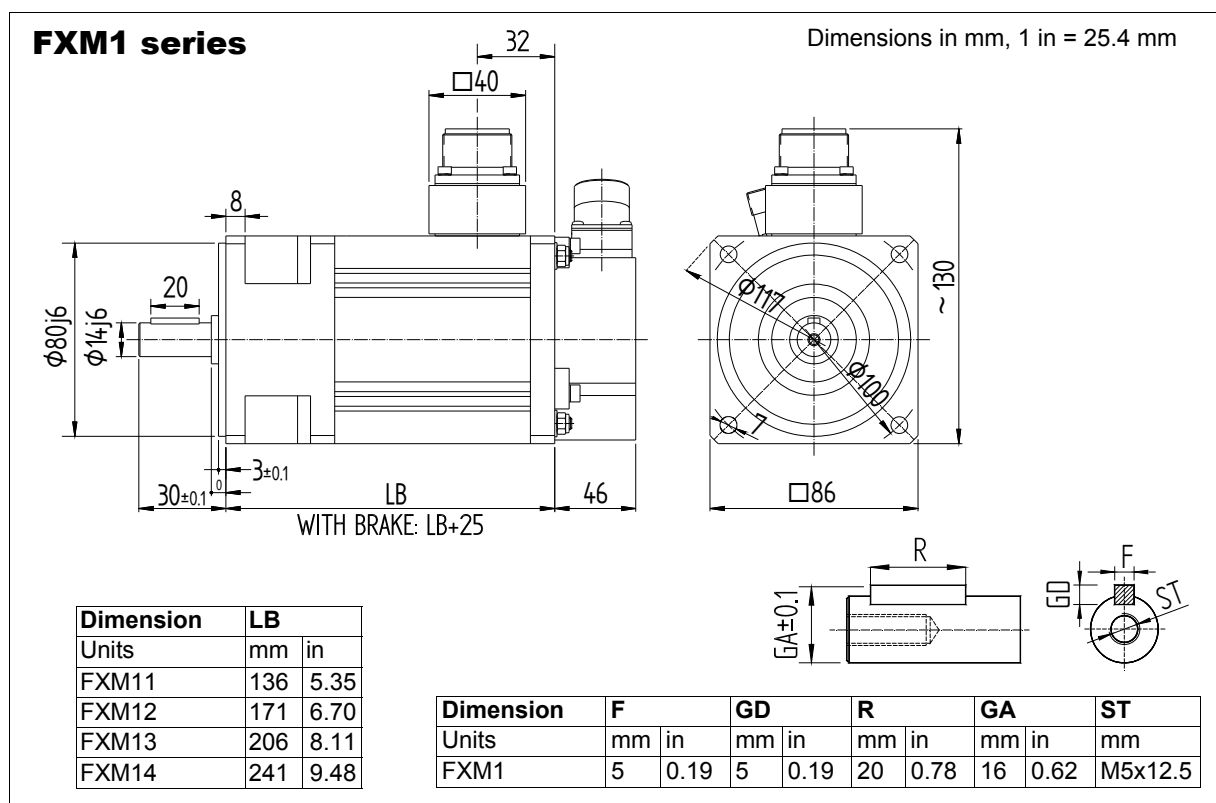

F. 1 Dimensions of FXM1 series motors.

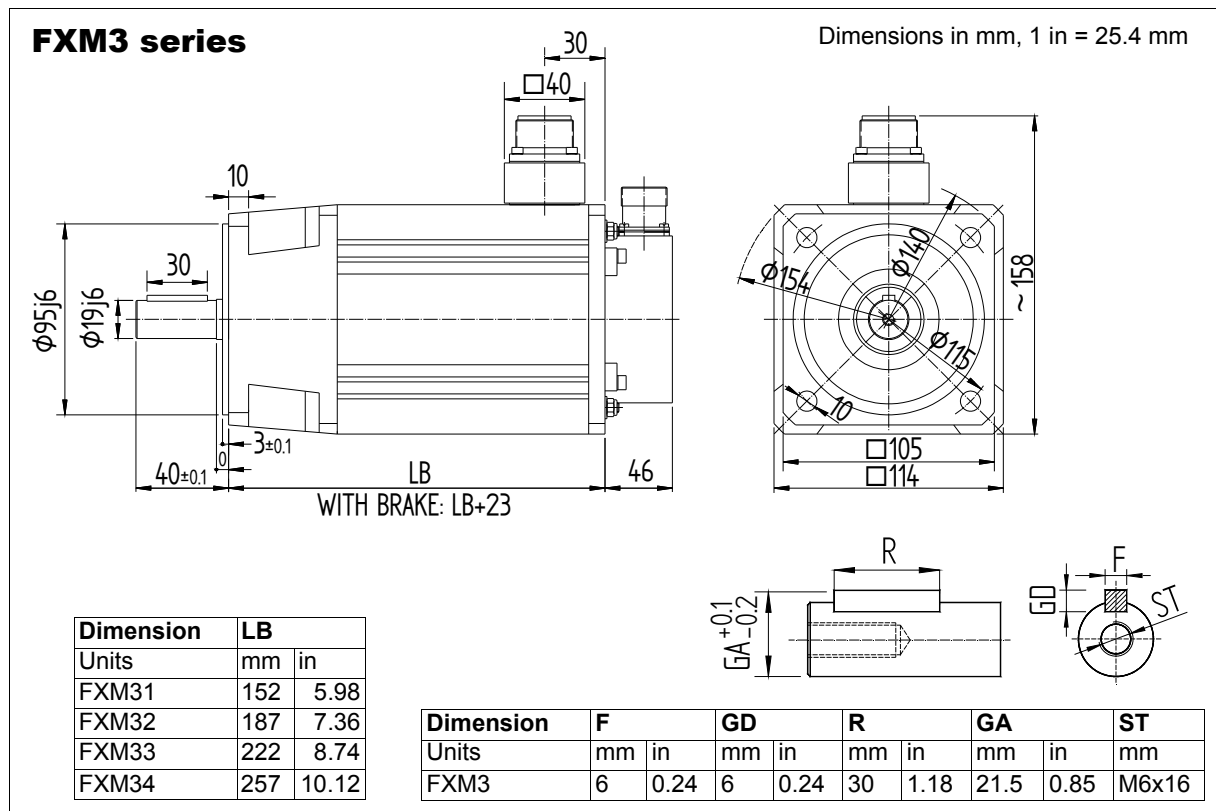

F. 2 Dimensions of FXM3 series motors.

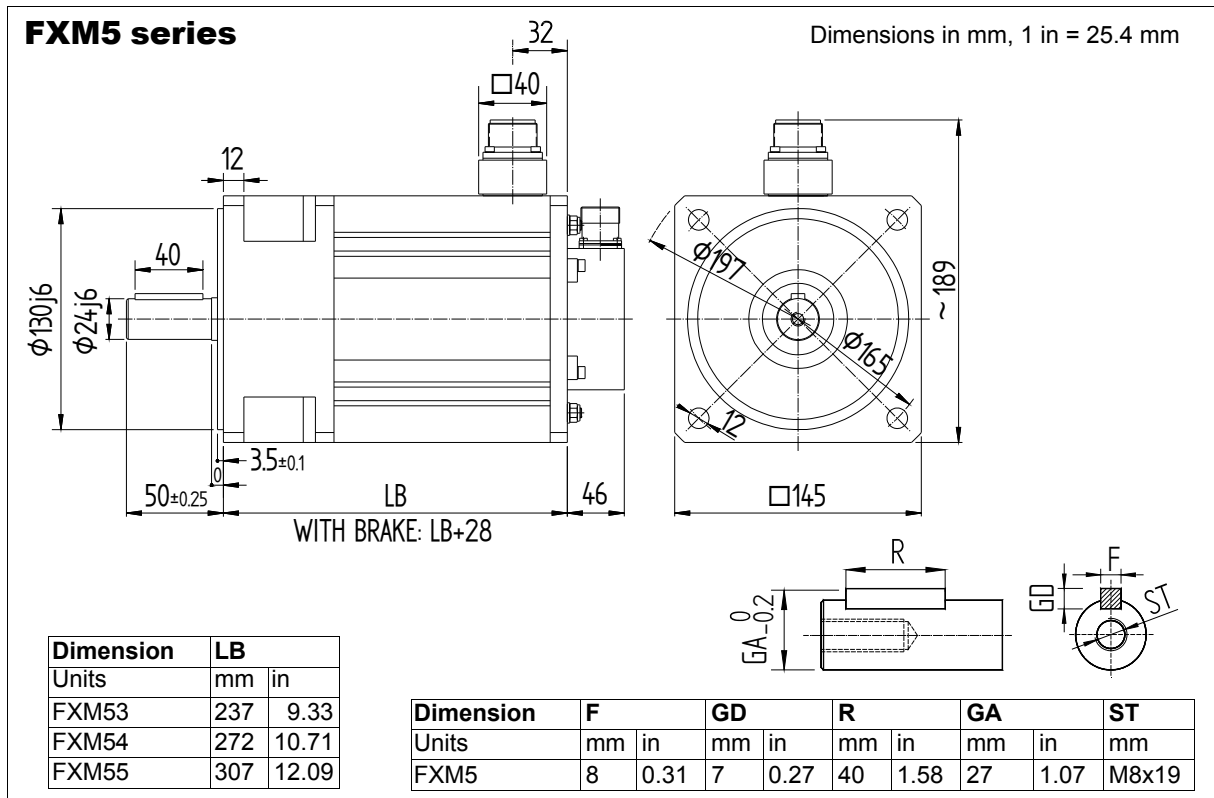

F. 3 Dimensions of FXM5 series motors.

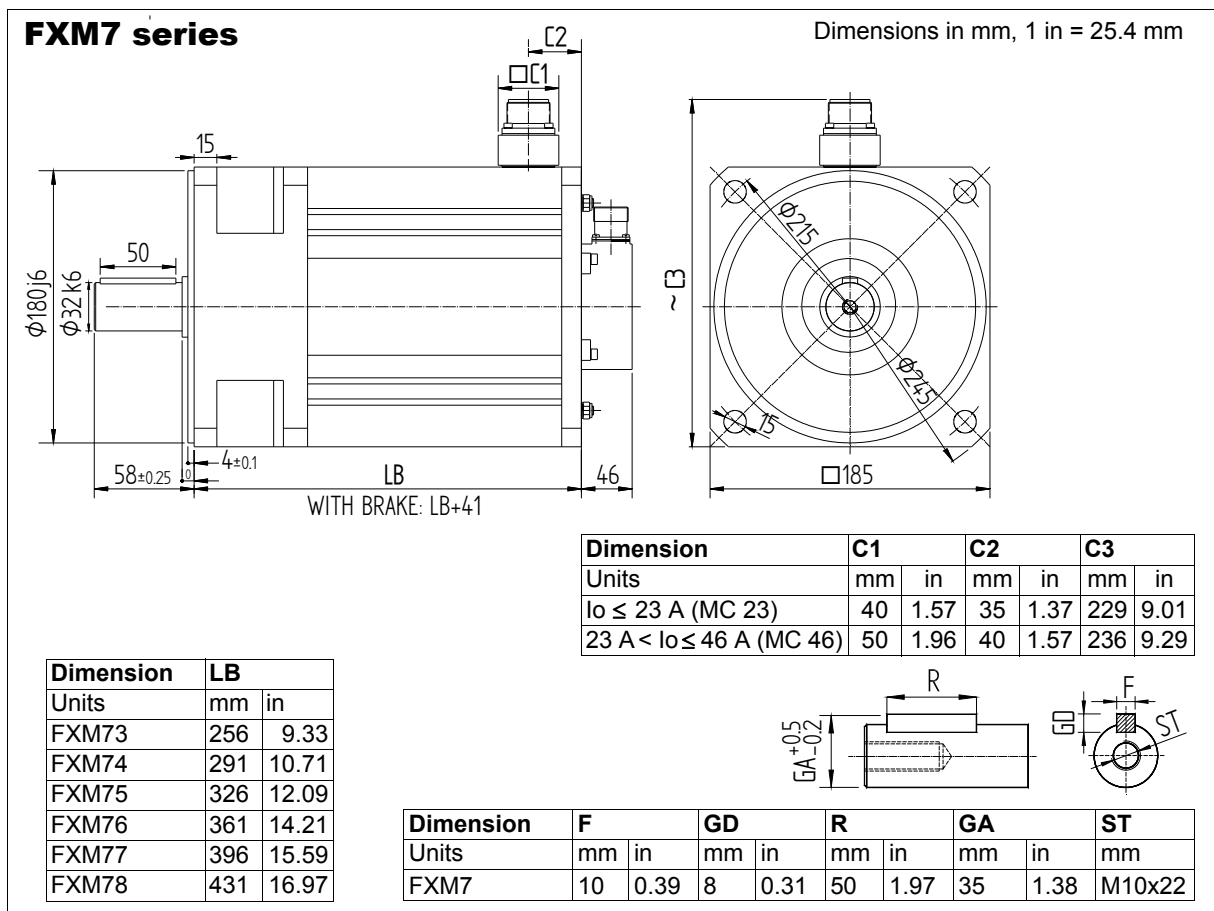

F. 4 Dimensions of FXM7 series motors.

Power connector

The power connector includes the brake terminals (E, F). A voltage between 22 and 26 V DC releases the shaft. When installing the motor, verify that the brake releases the shaft completely before turning it for the first time. Connecting the motor windings in the order indicated on the connector (U, V, W), the shaft will turn clockwise (CWR, **C**lock **W**ise **R**otation).

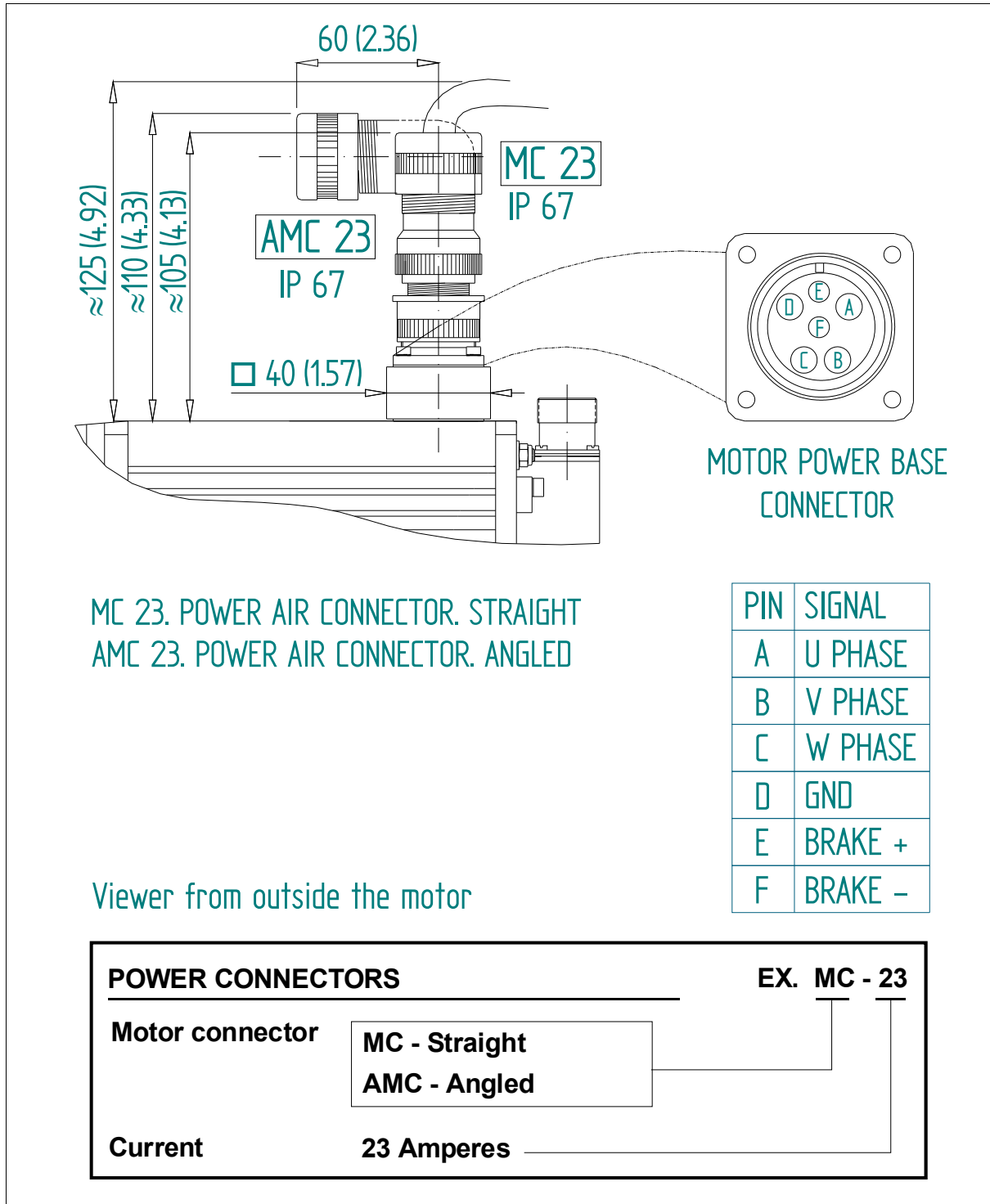

F. 5 MC-23 or AMC-23 power connector. Sales reference. Pinout and dimensions.

Motor feedback connector

Pins of 9 and 10 of the connector of the incremental TTL encoder correspond to the thermistor used to monitor motor overheating.

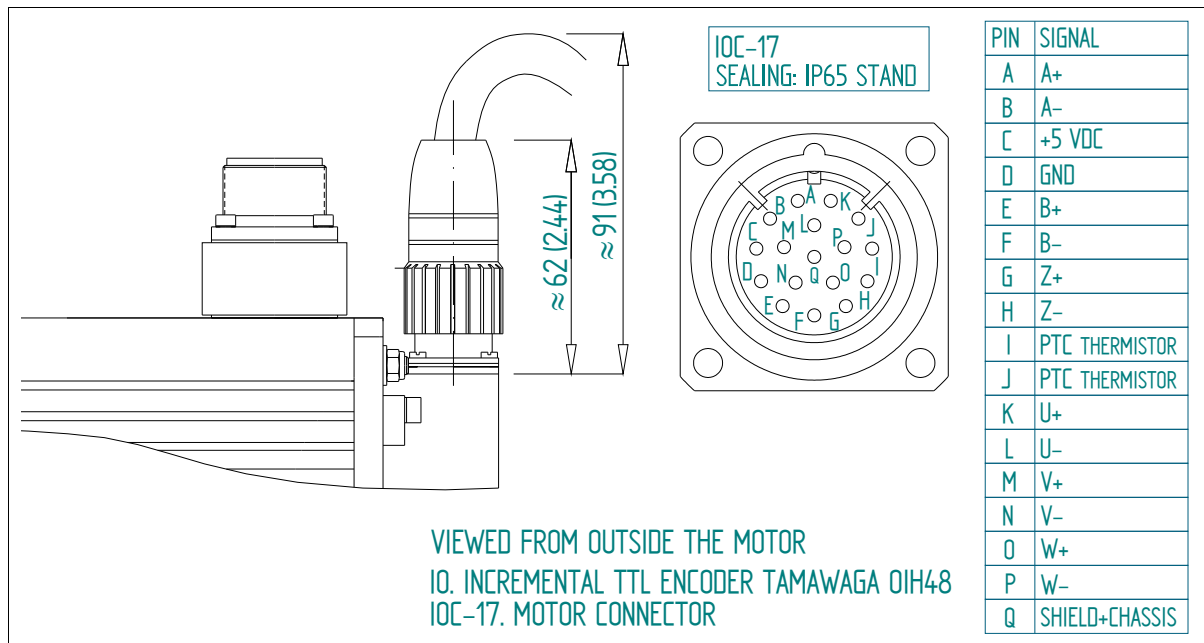

F. 6 Feedback connector, IOC-17. Incremental TTL encoder (ref. I0). Pinout and dimensions.

Pins of 3 and 4 of the SinCos or SinCoder encoder connector correspond to the thermistor used to monitor motor overheating.

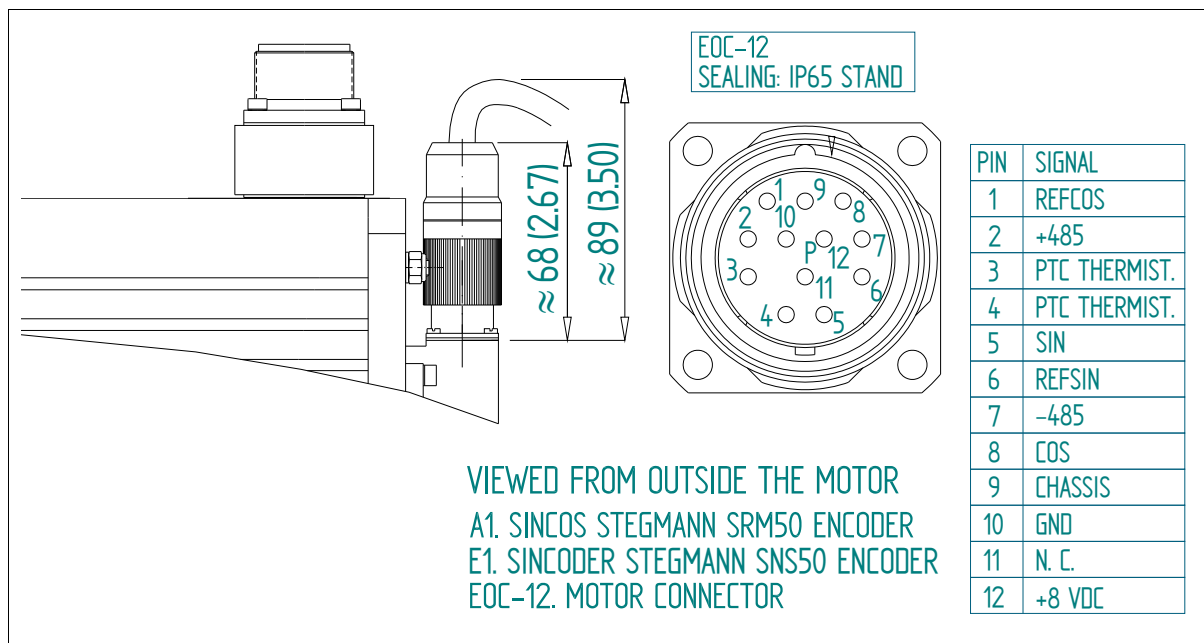

F. 7 Feedback connector, EOC-12. SinCos encoder (ref. A1) and SinCoder encoder (ref. E1). Pinout and dimensions.

Holding brake

FXM motors have an optional holding brake that applies friction to the shaft. Its purpose is to immobilize or lock vertical axes, not to brake a moving axis.

Technical data

The characteristics depending on the type of brake are:

T. 5 Technical data of the holding brake.

Motor	Holding torque		Power consumption		ON/OFF time	Releasing voltage margin	Inertia	Mass approx.	
	N·m	in·lbf	W	hp				kg	lbf
Units	N·m	in·lbf	W	hp	ms	V DC	kg·cm ²	kg	lbf
FXM1	Mo motor		12	0.016	19/29	22-26	0.38	0.3	0.66
FXM3	Mo motor		16	0.021	20/29	22-26	1.06	0.6	1.32
FXM5	Mo motor		18	0.024	25/50	22-26	3.60	1.1	2.42
FXM7	Mo motor		35	0.047	53/97	22-26	31.80	4.1	9.03

Nota. The maximum speed is 10000 rev/min, for all of them except for the brake that may be used on the FXM7 series that is 8000 rev/min.



WARNING. NEVER use this holding brake to stop a moving axis!



WARNING.

- The holding brake must never exceed its maximum turning speed.
- A voltage between 22 and 26 V DC releases the shaft. Make sure that no voltage over 26 V DC is applied that prevents the shaft from turning.
- When installing the motor, make sure that the holding brake fully releases the shaft before making it turn for the first time.

Sales reference

FXM □□.□□□.□□.□□□ - X □□									
FAGOR SYNCHRONOUS MOTOR									
SIZE	1, 3, 5, 7								
LENGTH	1, 2, 3, 4, 5								
RATED SPEED	<table border="0"> <tr> <td>12</td> <td>1200 rev/min</td> <td>20</td> <td>2000 rev/min</td> </tr> <tr> <td>30</td> <td>3000 rev/min</td> <td>40</td> <td>4000 rev/min</td> </tr> </table>	12	1200 rev/min	20	2000 rev/min	30	3000 rev/min	40	4000 rev/min
12	1200 rev/min	20	2000 rev/min						
30	3000 rev/min	40	4000 rev/min						
WINDING	<table border="0"> <tr> <td>F</td> <td>220 V AC</td> </tr> <tr> <td>A</td> <td>400 V AC</td> </tr> </table>	F	220 V AC	A	400 V AC				
F	220 V AC								
A	400 V AC								
FEEDBACK TYPE	<table border="0"> <tr> <td>I0</td> <td>Incremental encoder (2500 ppt)</td> </tr> <tr> <td>A1</td> <td>Absolute multi-turn SinCoder encoder (1024 ppt)</td> </tr> <tr> <td>E1</td> <td>SinCoder encoder (1024 ppt)</td> </tr> </table>	I0	Incremental encoder (2500 ppt)	A1	Absolute multi-turn SinCoder encoder (1024 ppt)	E1	SinCoder encoder (1024 ppt)		
I0	Incremental encoder (2500 ppt)								
A1	Absolute multi-turn SinCoder encoder (1024 ppt)								
E1	SinCoder encoder (1024 ppt)								
FLANGE & SHAFT	<table border="0"> <tr> <td>0</td> <td>IEC Standard</td> </tr> <tr> <td>1</td> <td>Keyless shaft</td> </tr> <tr> <td>8</td> <td>NEMA standard (USA)</td> </tr> <tr> <td>9</td> <td>Special</td> </tr> </table>	0	IEC Standard	1	Keyless shaft	8	NEMA standard (USA)	9	Special
0	IEC Standard								
1	Keyless shaft								
8	NEMA standard (USA)								
9	Special								
BRAKE OPTION	<table border="0"> <tr> <td>0</td> <td>Without brake</td> </tr> <tr> <td>1</td> <td>With standard brake (24 V DC)</td> </tr> </table>	0	Without brake	1	With standard brake (24 V DC)				
0	Without brake								
1	With standard brake (24 V DC)								
FAN	<table border="0"> <tr> <td>0</td> <td>Without fan</td> </tr> <tr> <td>1</td> <td>With Standard fan</td> </tr> <tr> <td>9</td> <td>With special fan</td> </tr> </table>	0	Without fan	1	With Standard fan	9	With special fan		
0	Without fan								
1	With Standard fan								
9	With special fan								
SPECIAL CONFIGURATION	X								
SPECIFICATION	01 → ZZ Only when it has a special configuration (X) !								

Notes.
 Encoders with reference:
I0, only available on FXM servomotors, "F" winding.
E1/A1, only available on FXM servomotors, "A" winding.

BRUSHLESS AC MOTORS, FKM

Introduction

FKM synchronous servo motors are AC brushless with permanent magnets.

They are ideal for any application requiring great positioning accuracy. They have a uniform output torque, high reliability and low maintenance.

They are designed to meet the IP 64 protection standard and, therefore, they are immune to liquid and dirt.

FKM2

FKM4

FKM6

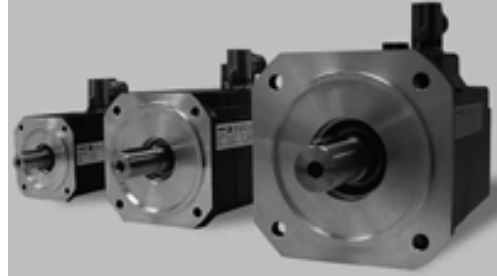

IP 64 means that is protected against dust and against water jets. They have a temperature sensor to monitor the internal temperature. They also carry an optional electromechanical holding brake. They have rotating power and feedback connectors. The F class isolation on the motor maintains the dielectric properties as long as the work temperature stays below 150°C/302°F.

General characteristics

T. 6 FKM servomotors. General characteristics.

Excitation	Permanent rare earth magnets (Nd-Fe-B)
Temperature sensor	Thermistor PTC KTY84-130 Thermistor PTC Pt1000 (shortly)
Shaft end	Cylindrical keyless (optional with keyway)
Mounting	Face flange with through holes
Mounting method	IM B5 - IM V1 - IM V3 (as recommended by IEC-34-3-72)
Mechanical tolerances	Normal class (meets IEC-72/1971)
Balancing	Class N (R optional) (DIN 45665) half-key balancing
Roller bearings' life	20000 hours
Noise	DIN 45635
Vibration resistance	Withstands 1g along the shaft and 3g sideways ($g=9.81m/s^2$)
Electrical insulation	Class F (150°C/302°F)
Insulation resistance	500 V DC, 10 MΩ or greater
Dielectric rigidity	1500 V AC, one minute
Protection degree	General: Standard IP 64. Shaft: Standard IP 64, IP 65 with oil seal
Storage temperature	-20°C/+80°C (-4°F/+176°F)
Ambient temperature	0°C/+40°C (+32°F/+104°F)
Working ambient	From 20% to 80% (non condensing)
Holding brake	Optional. See technical data ·holding brake·
Feedback	I0 Incremental TTL encoder ·2500 ppt· E3/A3 Sinusoidal encoder / Multi-turn abs. encoder ·1024 ppt·
Meaning of the codes of the mounting method	<p>IM B5 IM V1 IM V3</p>

T. 7 Technical data of non-ventilated synchronous FKM motors with “A” winding (400 V AC).

Non-ventilated motors	Stall torque		Rated speed	Stall current	Peak current	Calculation power	Torque constant	Acceleration time	Inductance per phase	Resistance per phase	Inertia ¹	Mass ²	Drive peak torque	
	Mo	Mp											ACSD-08H	ACSD-16H
	N·m	N·m	nN	Io	Imax	Pcal	kt	tac	L	R	J	M	N·m	N·m
FKM21.60A.□□.□□□□	1.7	7	6000	2.8	11	1.1	0.60	14.4	7.70	2.600	1.6	4.2	4.8	7.0
FKM22.30A.□□.□□□□	3.2	13	3000	2.4	10	1.0	1.33	7.0	16.00	3.950	2.9	5.3	10.4	13.0
FKM22.50A.□□.□□□□	3.2	13	5000	4.0	16	1.7	0.80	11.7	5.80	1.400	2.9	5.3	6.4	12.8
FKM22.60A.□□.□□□□	3.2	13	6000	4.5	18	2.0	0.71	14.0	4.60	1.100	2.9	5.3		11.3
FKM42.30A.□□.□□□□	6.3	25	3000	4.6	19	2.0	1.36	10.7	8.60	1.450	8.5	7.8		21.7
FKM42.45A.□□.□□□□	6.3	25	4500	6.9	28	3.0	0.91	16.0	3.90	0.675	8.5	7.8		14.5
FKM42.60A.□□.□□□□	6.3	25	6000	8.5	34	3.9	0.74	21.3	2.60	0.450	8.5	7.8		11.8
FKM43.20A.□□.□□□□	9.0	36	2000	3.9	15.7	1.88	2.30	9.7	14.5	1.720	16.7	11.7	18.4	36.0
FKM43.30A.□□.□□□□	9.0	36	3000	6.2	25	2.82	1.45	14.5	6.2	0.755	16.7	11.7		23.2
FKM43.40A.□□.□□□□	9.0	36	4000	9.4	38	3.77	0.95	19.4	2.4	0.315	16.7	11.7		15.2
FKM44.20A.□□.□□□□	11.6	47	2000	4.6	19	2.4	2.52	7.4	14.51	1.720	16.7	11.7		40.3
FKM44.30A.□□.□□□□	11.6	47	3000	8.2	33	3.6	1.41	11.2	4.20	0.540	16.7	11.7		22.5
FKM44.30A.□□.□□□□.2	11.6	47	3000	7.0	28	3.6	1.65	11.1	6.16	0.755	16.7	11.7		26.4
FKM62.30A.□□.□□□□	8.9	35	3000	7.1	28	2.8	1.25	14.4	7.20	0.770	16.0	11.9		20.0
FKM62.40A.□□.□□□□	8.9	35	4000	9.3	37	3.7	0.95	19.1	4.10	0.440	16.0	11.9		15.3
FKM63.20A.□□.□□□□	12.5	51	2000	5.3	21.3	2.6	2.35	12.1	13.2	0.935	29.5	17.1		37.6
FKM63.30A.□□.□□□□	12.5	51	3000	10.3	40.6	3.9	1.21	18.1	3.8	0.280	29.5	17.1		19.3
FKM64.20A.□□.□□□□	16.5	66	2000	6.5	26	3.4	2.53	9.3	13.16	0.935	29.5	17.1		40.6
FKM66.20A.□□.□□□□	23.5	94	2000	10.5	42	4.9	2.23	9.5	4.60	0.315	43.0	22.3		35.8
FKM66.20A.□□.□□□□.2	23.5	94	2000	9.4	37	4.9	2.50	9.5	8.82	0.410	43.0	22.3		40.0

1. Motor inertia without holding brake.
2. Motor mass without holding brake.

NOTE: In the combinations shown in bold letters, the drive will limit its peak current automatically so as not to damage the motor.

T. 8 Technical data of non-ventilated synchronous FKM motors with “F” winding (220 V AC).

Non-ventilated motors	Stall torque	Stall peak torque	Rated speed	Stall current	Peak current	Calculation power	Torque constant	Acceleration time	Inductance per phase	Resistance per phase	Inertia ¹	Mass ²	Drive peak torque		
	Mo N·m	Mp N·m	nN rpm	Io A	Imax A	Pcal kW	kt N·m/A	tac ms	L mH	R Ω	J kg·cm ²	M kg	ACSD-10L N·m	ACSD-20L N·m	ACSD-30L N·m
FKM21.60F.□□.□□□□	1.7	7	6000	4.7	19	1.1	0.36	14.4	2.6	0.885	1.6	4.2	3.6	7.0	-
FKM22.30F.□□.□□□□	3.2	13	3000	4.5	18	1.0	0.74	7.0	4.6	1.100	2.9	5.3	7.4	13.0	-
FKM22.50F.□□.□□□□	3.2	13	5000	7.2	29	1.7	0.45	11.7	1.7	0.425	2.9	5.3	3.6	9.0	13.0
FKM42.30F.□□.□□□□	6.3	25	3000	8.5	34	2.0	0.74	10.7	2.6	0.450	8.5	7.8	-	14.8	22.2
FKM42.45F.□□.□□□□	6.3	25	4500	12.4	50	3.0	0.51	16.0	1.2	0.210	8.5	7.8	-	18.2	25.0
FKM43.30F.□□.□□□□	9.0	36	3000	13.8	55.4	2.8	0.65	14.5	1.2	0.150	16.7	11.7	-	-	19.5
FKM44.30F.□□.□□□□	11.6	47	3000	15.6	62	3.6	0.74	11.2	1.2	0.150	16.7	11.7	-	-	22.2
FKM62.30F.□□.□□□□	8.9	35	3000	13.1	52	2.8	0.68	14.4	2.1	0.225	16.0	11.9	-	-	20.4
FKM62.40F.□□.□□□□	8.9	35	4000	16.4	66	3.7	0.54	19.1	1.3	0.180	16.0	11.9	-	-	16.2
FKM63.20F.□□.□□□□	12.5	51	2000	11.7	46.6	2.6	1.06	12.1	2.7	0.205	29.5	17.1	-	-	31.8
FKM63.30F.□□.□□□□	12.5	51	3000	16.6	66.4	3.9	0.75	18.1	1.3	0.100	29.5	17.1	-	-	22.5
FKM64.20F.□□.□□□□	16.5	66	2000	14.3	57	3.4	1.15	9.35	2.7	0.205	29.5	17.1	-	-	34.5
FKM64.30F.□□.□□□□	16.5	66	3000	20.0	80	5.1	0.82	14.0	1.3	0.145	29.5	17.1	-	-	24.6
FKM66.20F.□□.□□□□	23.5	94	2000	19.2	76.8	4.9	1.22	9.57	0.8	0.135	43.0	22.3	-	-	36.6

1. Motor inertia without holding brake.

2. Motor mass without holding brake.

NOTE. In the combinations shown in bold letters, the drive will limit its peak current automatically so as not to damage the motor.

Dimensions

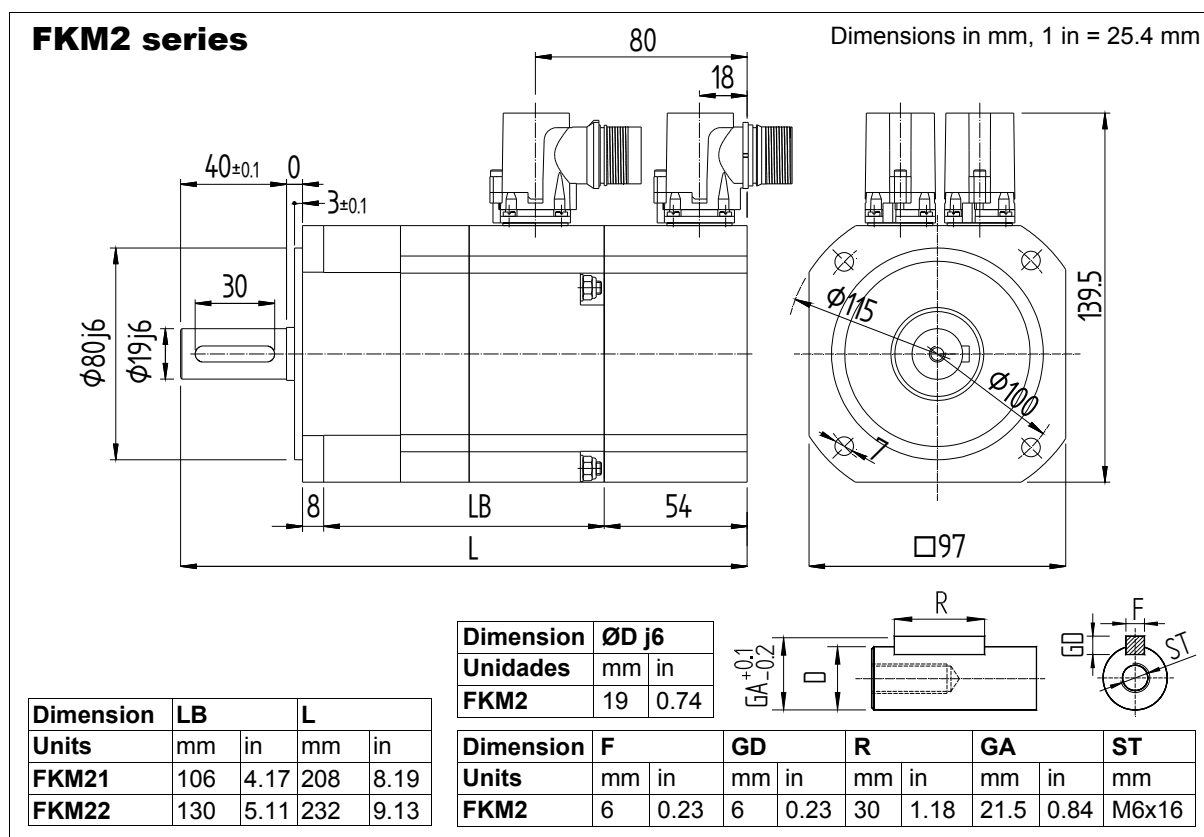

F. 8 Dimensions of FKM2 series motors.

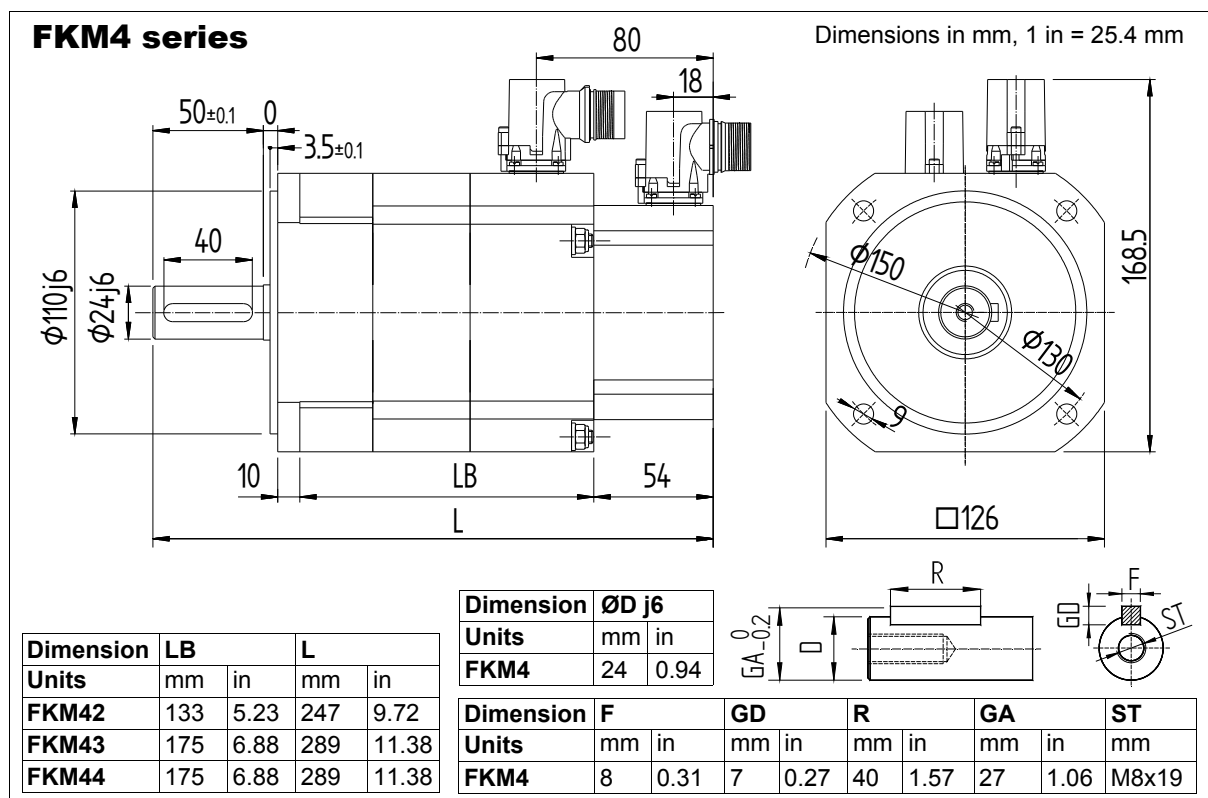

F. 9 Dimensions of FKM4 series motors.

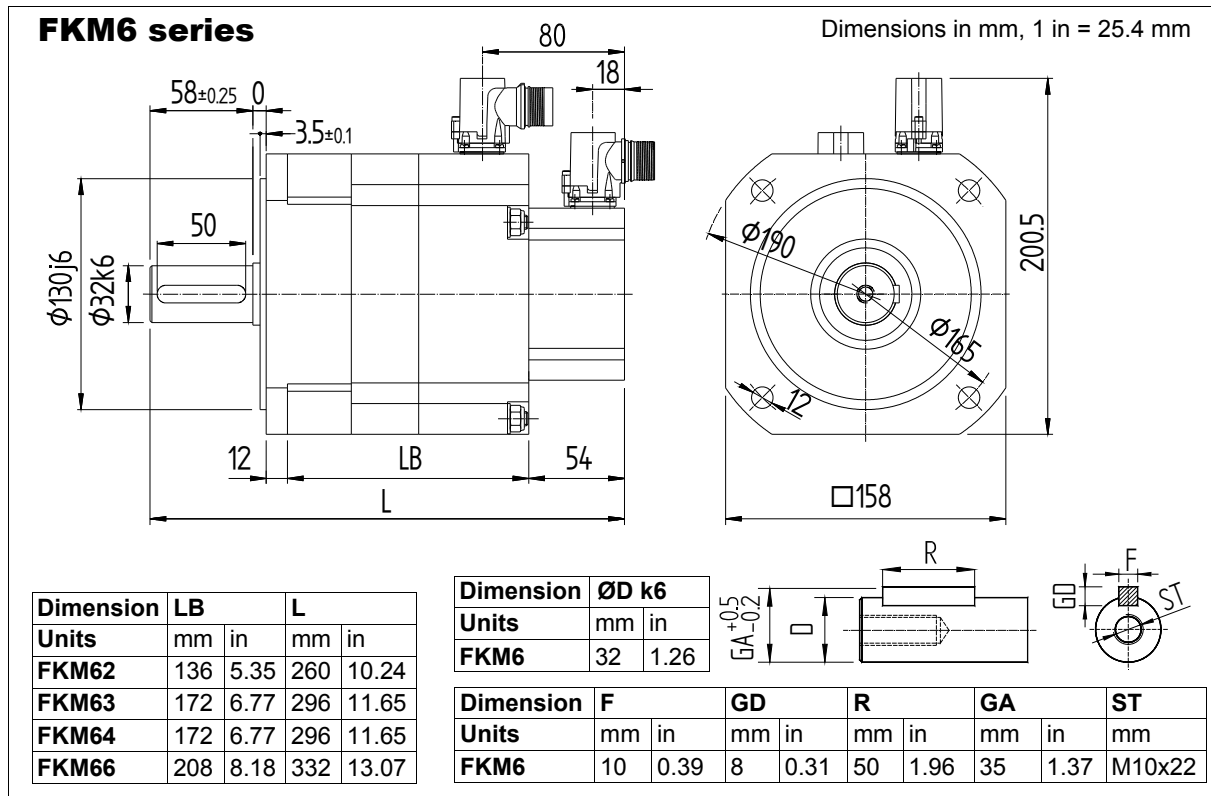

F. 10 Dimensions of FKM6 series motors.

Power connector

It includes the connectors of the brake itself (pins 4 and 5). A voltage between 22 and 26 V DC releases the shaft. When installing the motor, verify that the brake releases the shaft completely before turning it for the first time. Connecting the motor windings in the order indicated on the connector (U, V, W), the shaft will turn clockwise (CWR, Clock Wise Rotation).

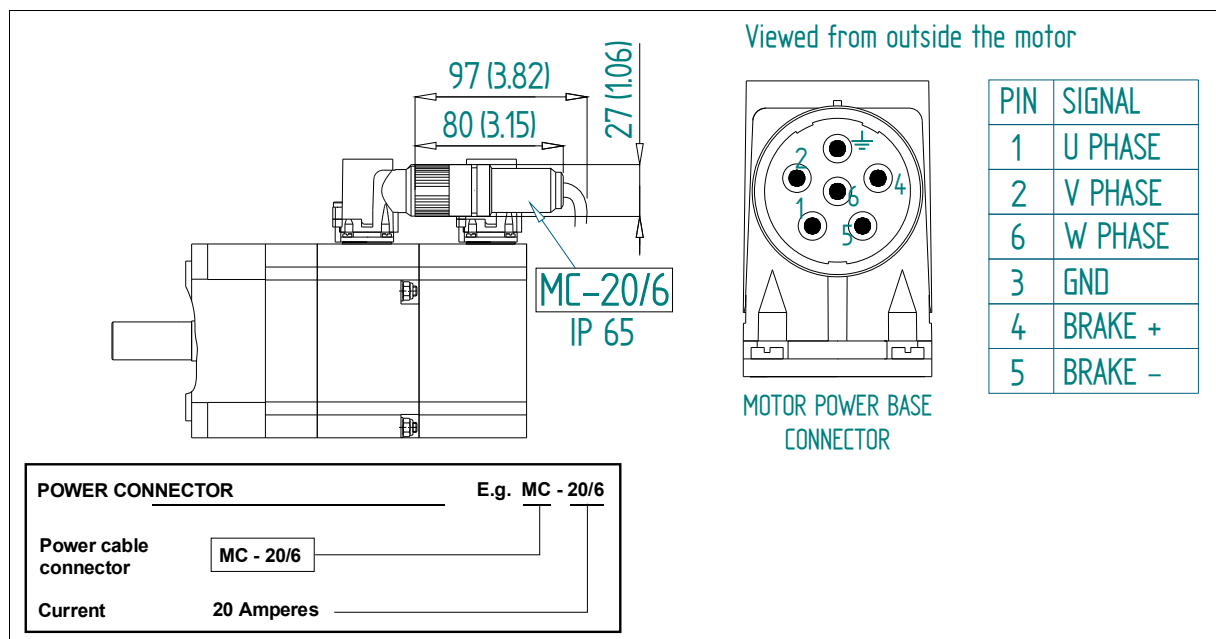

F. 11 Power connector, MC-20/6. Sales reference, pinout and dimensions.

Motor feedback connector

Pins 9 and 10 on the connector of the TTL incremental encoder (ref. I0) correspond to the thermal sensor of the motor that monitors its heating. Note that the PTC KTY84-130 thermistor has polarity, (pin 9 - / pin10 +), while the PTC Pt1000 does not.

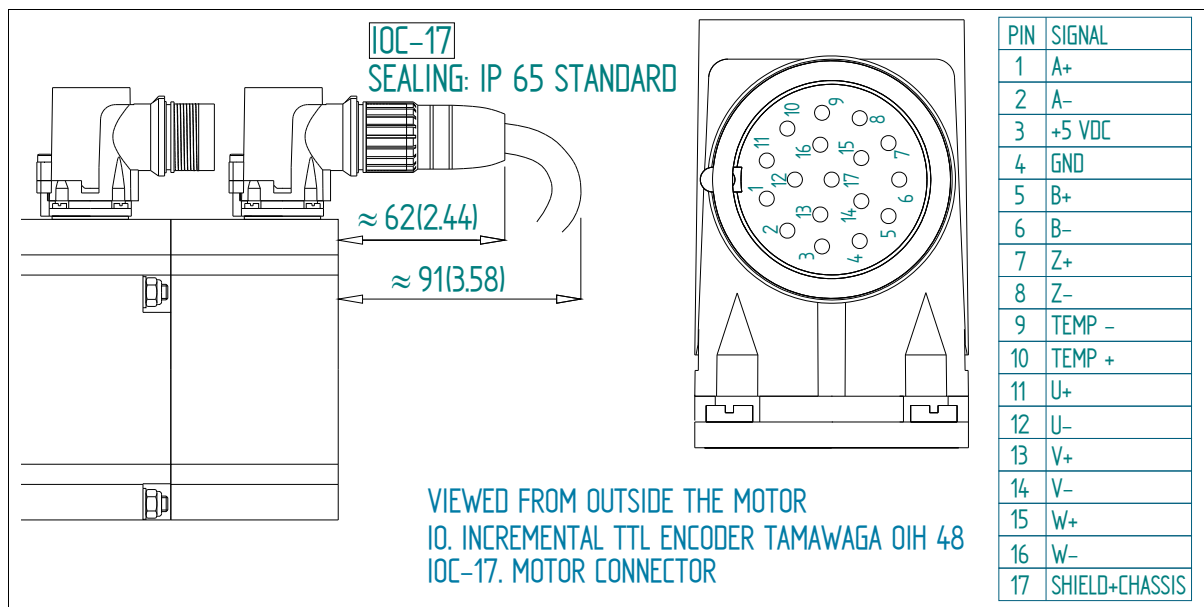

F. 12 Feedback connector, IOC-17. TTL incremental encoder (ref. I0). Pinout and dimensions.

Pins 3 and 4 on the connector of the SinCos encoder (refs. E3/A3) correspond to the thermal sensor of the motor that monitors its heating. Note that the PTC KTY84-130 thermistor has polarity (pin 3 - / pin 4 +), while the PTC Pt1000 does not.

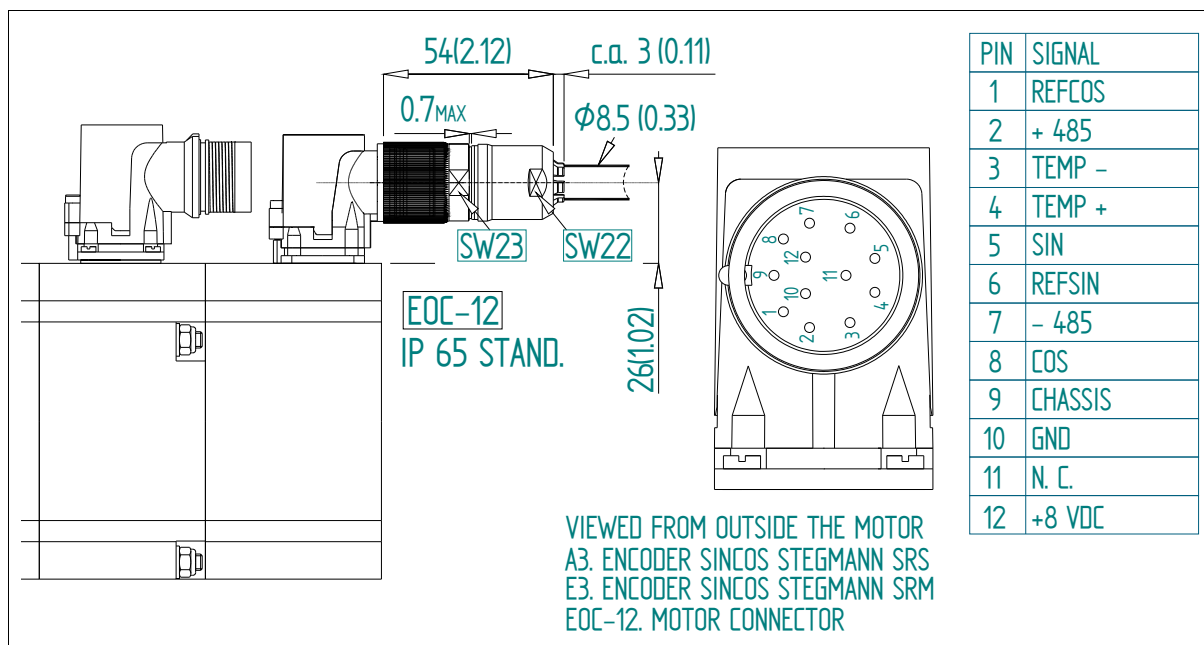

F. 13 Feedback connector, EOC-12. SinCos encoder (refs. E3/A3). Pinout and dimensions.

Holding brake

FKM motors have an optional holding brake that applies friction to the shaft. Its purpose is to immobilize or lock vertical axes, not to brake a moving axis.

Technical data

Its main characteristics depending on the type of brake are:

T. 9 Technical data of the holding brake.

Motor	Holding torque		Power consumption		ON/OFF time	Range of releasing voltage	Inertia	Mass approx.	
	Units	N·m	lbf·ft	W				hp	ms
FKM2	4.5	3.32	12	0.016	7/35	22-26	0.18	0.30	0.66
FKM4	9.0	6.64	18	0.024	7/40	22-26	0.54	0.48	1.06
FKM6	18.0	13.28	24	0.032	10/50	22-26	1.66	0.87	1.92

Note. Maximum speed for all of them is 10000 rev/min.



WARNING. NEVER use this holding brake to stop a moving axis.



WARNING.

- The holding brake must never exceed its maximum turning speed.
 - Voltage between 22 and 26 V DC releases the shaft. Make sure that no voltage over 26 V DC is applied that prevents the shaft from turning.
 - When installing the motor, make sure that the brake fully releases the shaft before making it turn for the first time.
-

Sales reference

FKM		□□	□□□	□□	□□□□	□□	□□	-	K□□
MOTOR SERIES									
SIZE	2, 4, 6								
LENGTH	1, 2, 3, 4, 6								
RATED SPEED	20	2000 rev/min	45	4500 rev/min					
	30	3000 rev/min	50	5000 rev/min					
	40	4000 rev/min	60	6000 rev/min					
WINDING	A	400 V AC							
	F	220 V AC							
FEEDBACK TYPE	A3 Multi-turn absolute sinusoidal 1Vpp · 1024 ppt· (taper shaft) E3 Sinusoidal 1Vpp encoder · 1024 ppt· (taper shaft) I0 TTL incremental encoder · 2500 ppt·								
FLANGE AND SHAFT	0	With keyway (half-key balancing)							
	1	Cylindrical (with no keyway)							
	2	Shaft with keyway and seal							
	3	Keyless shaft with seal							
	9	Special configuration							
BRAKE OPTION	0	Without brake							
	1	With standard brake · 24 V DC ·							
	2	With extra brake · 24 V DC ·							
FAN AND INERTIA OPTION	0	Standard							
	1	Electro-ventilated							
	8	Low inertia							
	9	Low inertia and electro-ventilated (future)							
WINDING OPTION	None	Standard							
	2	Optimized for ACSD-16H							
	3	Small size							
TEMPERATURE SENSOR	0/none	PTC KTY84							
	1	PTC Pt1000 (future)							
EXTRAS	-	None							
	K	Special configuration							
	U	NRTL SAFET certification (future)							
SPECIFICATION	01 ... 99	Only when it has a special configuration "K"							

Notes.

Encoders with reference:

I0, only available on FKM2/4/6 servomotors, "F" winding.

E3/A3, only available on FKM2/4/6 servomotors, "A" winding.

The type of temperature sensor that is incorporated in the servomotor is identified in the corresponding field shown in the figure and is stored in the memory of the feedback device.

COMPACT SERVO DRIVE, ACSD

Introduction

ACSD is a compact speed servo drive family for controlling synchronous AC brushless servomotors.

It has two series depending on the supply voltage they can be connected to: Hence, we will refer to:

ACSD (H series) if the power supply voltage is 400 V AC

ACSD (L series) if the power supply voltage is 220 V AC

where each of them will have the following models depending on their peak current:

For the “ACSD-xxH” series:

ACSD-04H	ACSD-08H	ACSD-16H	
-----------------	-----------------	-----------------	--

with peak currents of 4, 8 and 16 A.

For the “ACSD-xxL” series:

ACSD-05L	ACSD-10L	ACSD-20L	ACSD-30L
-----------------	-----------------	-----------------	-----------------

with peak currents of 5, 10, 20 and 30 A.

General characteristics

Their main characteristics are:

- Three phase power supply.
- Dynamic braking in case of mains failure.
- PWM IGBTs.
- 2500-line incremental TTL encoder feedback or 1Vpp sinusoidal encoder.
- CAN field bus communication interface.
- Two logic inputs to control the motor (speed enable and drive enable).
- One programmable logic input.
- One programmable logic output.
- “On-line” parameter editing.
- Typical protections in velocity drives.
- RS-232 communication (only for uploading software).
- CANopen communication protocol.

Dimensions

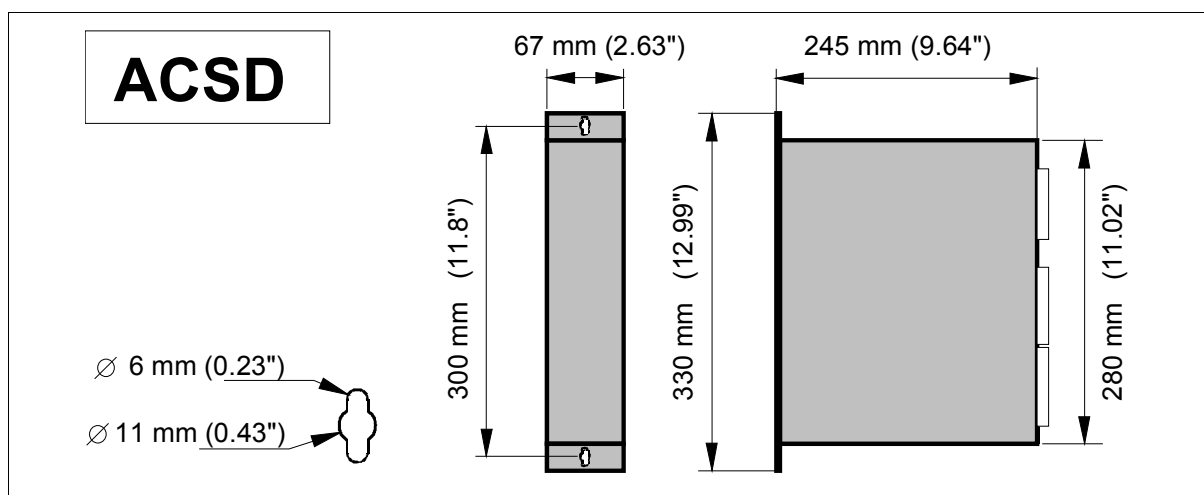

F. 14 ACSD drives. Dimensions.

Technical data

	· 220 V · L series				· 400 V · H series		
	05	10	20	30	04	08	16
Rated output current (A)	2.5	5	10	15	2	4	8
Peak current (0.5 s) (A)	5	10	20	30	4	8	16
Power supply	3 AC 220/240 V ± 10 % 50/60 Hz ± 10 %				3 AC 400/460 V ± 10 % 50/60 Hz ± 10 %		
Consumption (A)	5.6	11.1	22.2	33.3	4.4	8.9	16.7
Consumption (A) On single-phase models*	9.5	18.5	-	-	-	-	-
Over-voltage protection	430 V DC				803 V DC		
Frequency	Lower than 600 Hz						
Internal Ballast (Ω)	112	56	28	18	132	132	66
Power of the internal Ballast	150 W						
Ballast trigger	416 V DC				780 V DC		
Thermal protection of the heatsink	90°C/194°F						
Operating temperature	5°C/45°C (41°F/113°F)						
Storage temperature	- 20°C/60°C (-4°F/140°F)						
Protection degree	IP 20						
Dimensions	67 x 280 x 245 mm (2.48 x 11.8 x 9.05 in)						
Mass	3.85 kg (8.5 lb)						

IP 20 means that it is protected against objects of a diameter larger than 12.5 mm, but not against water splashes. Put the unit inside an electrical cabinet.



INFORMATION. * Modules ACSD-05L and ACSD-10L (220 V AC) may be supplied with a single-phase power voltage. See GP16.

Connectors

Power terminals

POWER INPUTS L1, L2, L3. Mains input terminals.

POWER OUTPUTS U, V, W. Output terminals for the voltage applied to the motor. Current control with PWM on a carrier frequency of 8 kHz. When connecting to the motor, watch the matching of phases U-U, V-V and W-W.

L+, Ri, Re. Terminals to configure and connect the external ballast resistor.

CONTROL POWER INPUTS L1, L2, GROUND (X3). Input terminals for the voltage supply of the drive's control circuits from mains. The maximum cable section at these power terminals is **2.5 mm²**. Total isolation between the power and the control circuits.

ACTIVATION OF THE INTERNAL FAN. The internal fan that cools the drive's power elements starts when enabling the Drive_Enable signal. The fan will stop when the heatsink temperature is lower than 70 °C since the Drive_Enable signal is turned off. This method decreases the fan's operating time, hence increasing its useful life.

Control signals

20 mA OUT

Voltage \pm 12 V, (pins 1, 2, 3 of X1). Output of an internal power supply so the user can easily generate a device enabling signal.

PROG. DIGIT. OUTPUT

Programmable digital output (pins 1 and 2 of X2). Opto-coupled open collector output. Max. current (100 mA), max. voltage (50 V).

ENABLES

Common, (pin 5 of X2). Reference point for the following:

Drive Enable, (pin 4 of X2). No current can flow through the motor winding at 0 V DC, i.e. without torque.

Speed Enable, (pin 3 of X2). At 0 V DC, it forces an internal zero velocity command.

NOTE. These control signals are activated with + 24 V DC.

DRIVE OK.

Drive Ok. (pins 6 and 7 of X2). Relay contact that closes when the internal status of the drive control is OK. It must be included in the electrical maneuver.

PROG. DIGIT. INPUT

Programmable digital input, (pins 8 and 9 of X2). Programmable digital input.

MOTOR FEEDBACK INPUT

Input connector of the encoder signals installed on the motor for “position + velocity” feedback and of the temperature sensor of the motor.

NOTE. The maximum cable section at these terminals is 0.5 mm ² . See chapter INSTALLATION .
--

RS232 COMMUNICATIONS

Connector for downloading the software version from a PC to the drive through the RS-232 serial line.

CAN BUS

CANopen bus card
(meets DS-301 standard regarding communications).

GNDa	pin 1 (X4)	Not connected
CANL	pin 2 (X4)	L input
SHIELD	pin 3 (X4)	Cable shield
CANH	pin 4 (X4)	H input
SHIELD	pin 5 (X4)	Not connected

Indicators

BUS ACTIVITY. Indicator light on top of the CAN bus connector (X4). It has several lighting sequences that indicate the status of both the CAN and of the drive. For further detail, see section **Initialization and adjustment** of this manual.

+ 5 V. Indicator light located to the right of the BUS ACTIVITY indicator. When lit, it indicates that the internal + 5 V are being applied.

CROWBAR (ON). Indicator light on top of the **RESET** button. When lit, it indicates that the voltage of the internal bus has exceeded the preset voltage values and the ballast resistor has been activated.

VBUS OK. Indicator light on top of the **RESET** button. When lit, it indicates that there is power voltage.

Push-buttons and switches

RESET. Push-button for resetting the system.

NODE SELECT. Rotary switch that sets the node number assigned to the drive on the CAN bus. For further detail, see section **Initialization and adjustment** of this manual.

SPEED SELECT. Switch that allows selecting the communication speed of the CAN bus. For further detail, see section **Initialization and adjustment** of this manual.

TERMINAL RESISTOR

Selector that, when in the “ON” position, connects the line terminating resistor between CANL and CANH of the bus.

Always activate **ON** at the drive connected at the farthest end of the bus cable.

At the rest of the drives that make up the system, **ON** must always be deactivated.

See attached figure.

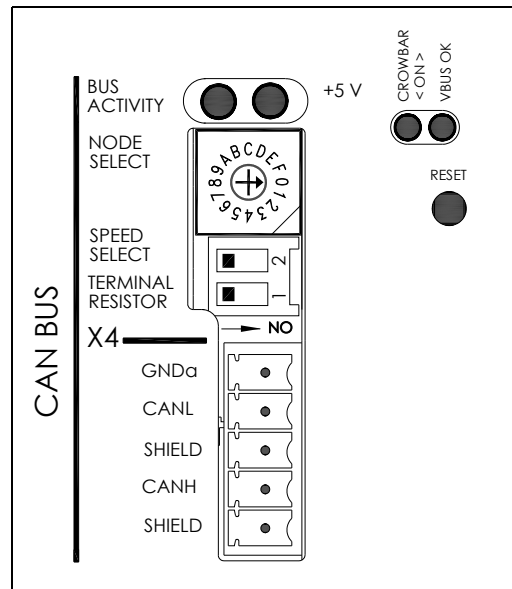

Front panel and pinout of the connectors

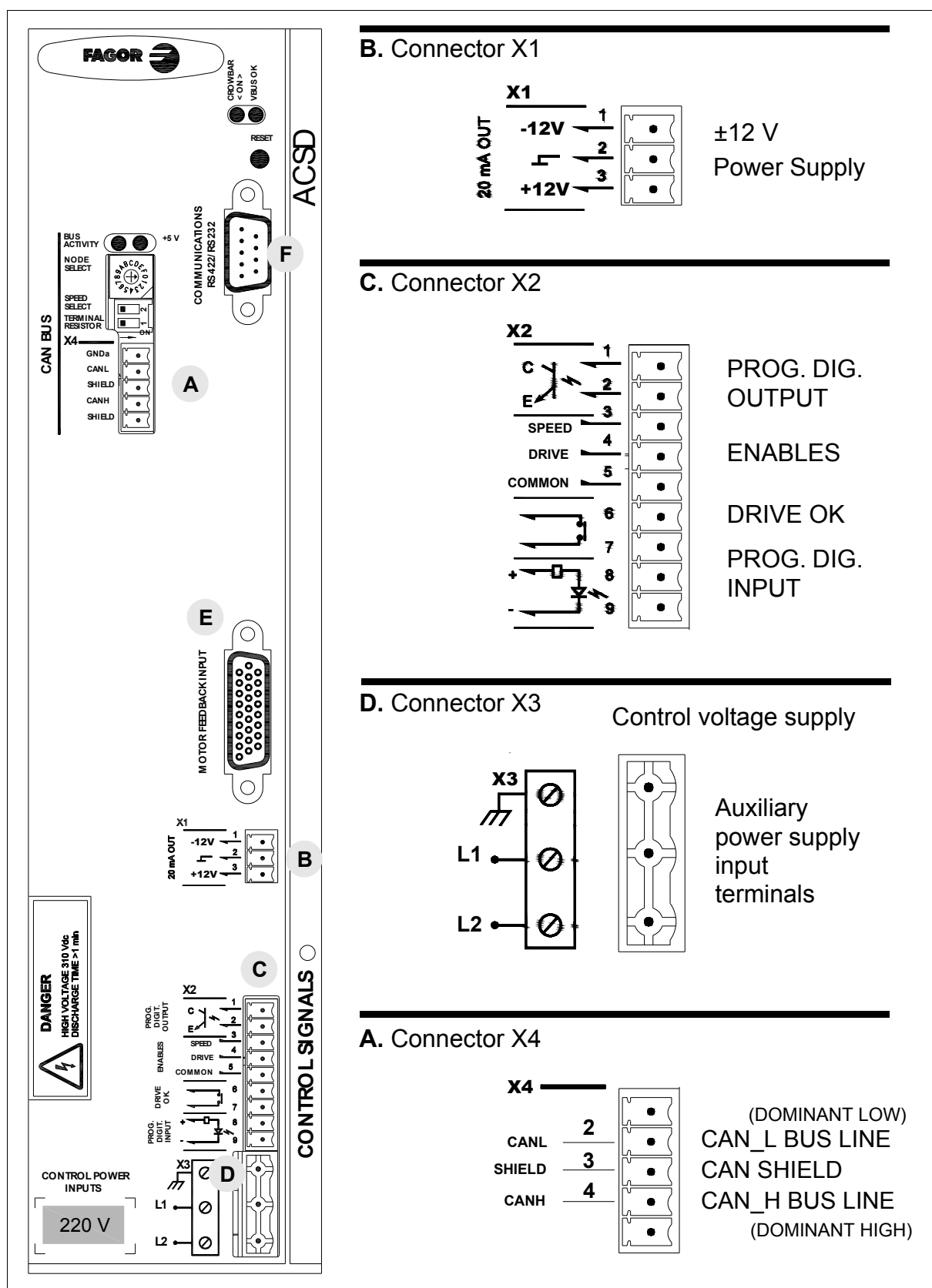

F. 15 Front panel and pinout of its connectors.

NOTE. The label 220 V AC will indicate 400 V AC on the corresponding models.

E. Input connector for motor feedback and temperature sensor.

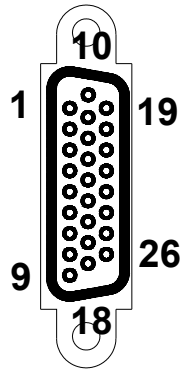

Pin	Signal	Function
1	A+	A + signal
2	B+	B + signal
3	Z+	Z + signal
4	U-	Phase switching U -
5	W-	Phase switching W -
6	V-	Phase switching V -
7	N.C.	Not connected
8	N.C.	
9	N.C.	
10	A-	A - signal
11	B-	B - signal
12	Z-	Z - signal
13	U+	Phase switching U +
14	W+	Phase switching W +
15	V+	Phase switching V +
16	N.C.	Not connected
17	SELSEN1	Information of the installed sensor given to the drive via hardware
18	SELSEN2	
19	+ 485	RS-485 serial line for sinusoidal encoder (refs. E1/A1/E3/A3)
20	- 485	
21	TEMP -	Thermal sensor of the motor PTC KTY-84 or PTC Pt1000
22	TEMP +	
23	+8VDC	Supply voltage for the sinusoidal encoder (refs. E1/A1/E3/A3)
24	+5VDC	Supply voltage for the incremental encoder (ref. I0)
25	GND	0 Volts
26	CHASSIS	Pin
	CHASSIS	Screws

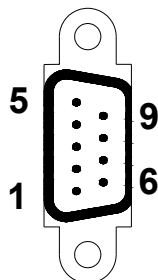

F. Communications connector



Pin	Signal	Function
1	N.C.	Not connected
2	R x D	R x D (232)
3	T x D	T x D (232)
4	+ 5V	Voltage supply
5	GND	GND
	CHASSIS	Screws

Unit identification

The specifications and version labels that come with each FAGOR ACSD digital drive show the following information:

Fagor Automation S.Coop. (Spain) **FAGOR**   (A)

MODEL: ACSD-16H

SN:  (SN) **10800251609XXXX**

VER: SOF SOFP MOT CAN CTR POT VAR
XX.XX X.X XX 02A XXX XXX XXX

(B) MODEL: ACSD-16H

INPUT: 3 x 400 VAC 50-60 Hz

Io: 8 A I_{max}: 16 A

F. 16 A. Version label. **B.** Characteristics label.

SOF, SOFP, MOT, CAN, CTR, POT and VAR indicate manufacturing related aspects (hardware design versions) that are useful for technical consultations and repairs.

Sales reference

Codes of the sales reference of FAGOR ACSD drives.

ACSD DIGITAL DRIVE EX. **ACSD - 05 L**

Model **ACSD** _____

Current (A)	Rated	Peak (0.5 s)
05	2.5	5.0
10	5.0	10.0
20	10.0	20.0
30	15.0	30.0

Supply Voltage 220 V AC _____

ACSD DIGITAL DRIVE EX. **ACSD - 04 H**

Model **ACSD** _____

Current (A)	Rated	Peak (0.5 s)
04	2.0	4.0
08	4.0	8.0
16	8.0	16.0

Supply Voltage 400 V AC _____

F. 17 Sales reference.

INSTALLATION

General considerations

At the motor

Remove the anti-corrosion paint of the shaft before mounting them on to the machine.

The motor may be mounted as IM B5, IM V1 and IM V3.

Watch for the ambient conditions mentioned in the section on general characteristics and also:

- Start the drive up (or do a reset) with the rotary switch in the “0” position.
- Mount it somewhere that is dry, clean and accessible for maintenance.

NOTE. Remember that the degree of protection is IP 64.

- It must be easily cooled.
- Avoid corrosive or flammable environments.
- Guard the motor with a cover if it is exposed to splashes.
- Use flexible coupling for direct transmission.
- Avoid radial and axial loads on the motor shaft.



MANDATORY. Do not hit the shaft when installing transmission pulleys or gears!

Use some tool that is supported in the threaded hole on the shaft to insert the pulley or the gear.

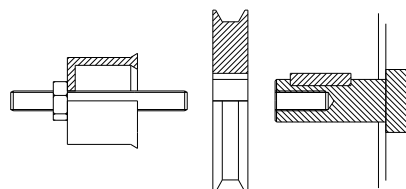

At the drive

The module must be installed in an electrical cabinet that is clean, dry, free of dust, oil and other pollutants.

NOTE. Remember that the degree of protection is IP 20.

Never install it exposing it to flammable gases. Avoid excessive heat and humidity. The ambient temperature must never exceed 45°C/113°F. Install the modules vertically, avoid vibrations and respect the gaps to allow air flow. See figure F. 18.

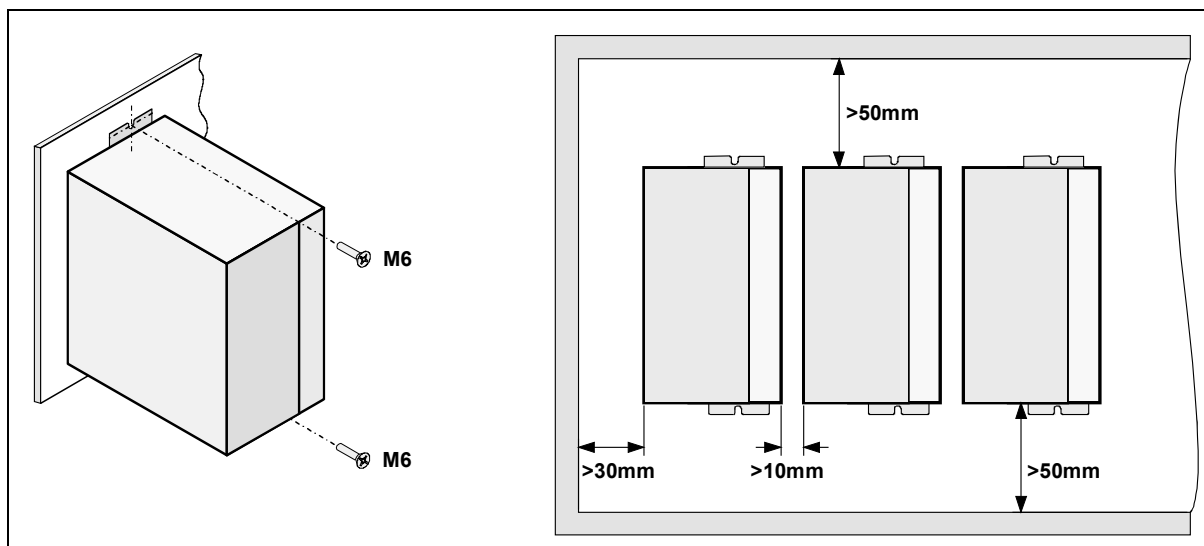

F. 18 Installation of ACSD modules.

About the connection

All the cables must be shielded, to reduce the interference on the control of the motor due to the commutation of the PWM. The shield of the motor power cable must be connected to the chassis screw at the bottom of the module and it, in turn, to mains ground.

NOTE. Keep the signal cables away from the power cables.

Electrical connections

Power connection. Mains - Drive

The power supply of “ACSD-xxL” units must be three-phase 220 V AC, except in modules ACSD-05L and ACSD-10L that can also be single-phase if parameter GP16 has been properly set. ACSD-xxH units must always be powered with three-phase 400 V AC. Parameter GP16 is ignored for these models.



INFORMATION. If ACSD-20L and ACSD-30L (220 V AC) units were powered with single-phase voltage, the software would limit the current to 10 A.



INFORMATION. Do not power ACSD-xxH (400 V AC) units with single-phase power voltage. The necessary bus voltage will never be reached.

NOTE. The use of a transformer is not a must.

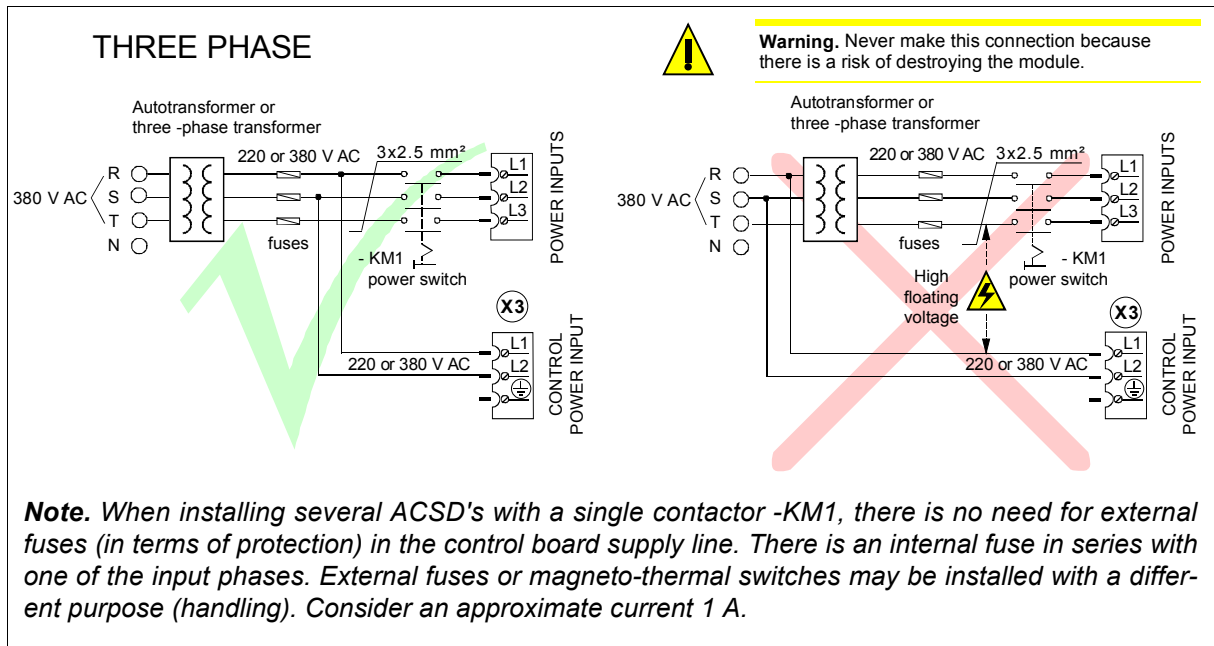

F. 19 Three-phase drive connection to mains.

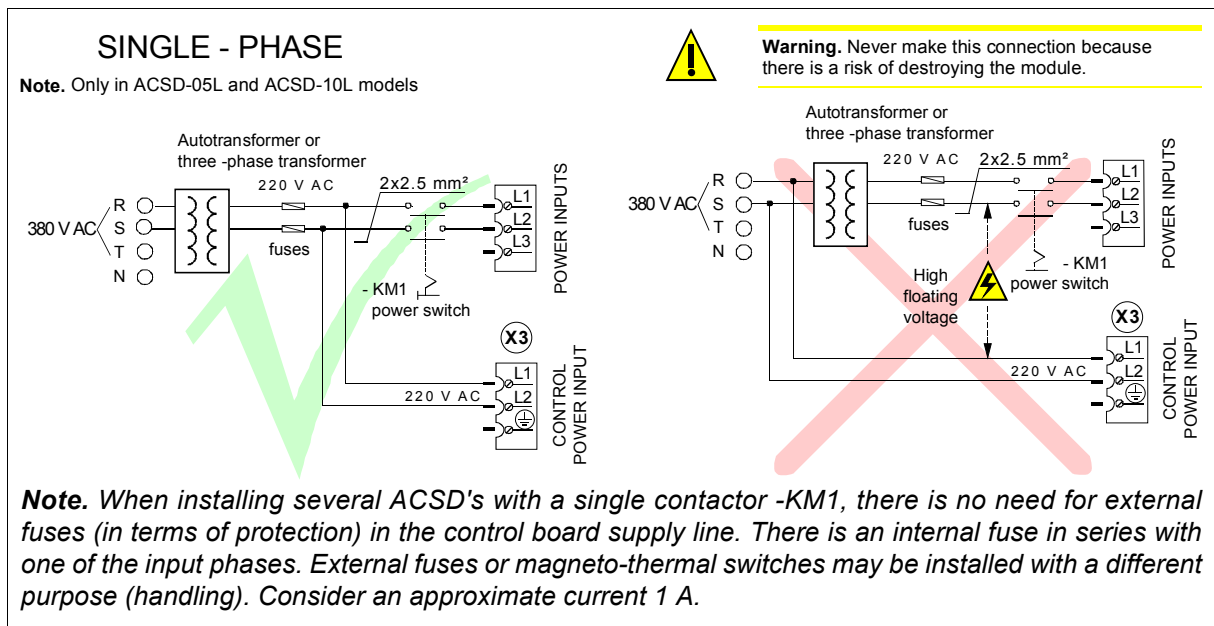

F. 20 Connection of the single-phase drive (only ACSD-05L and ACSD-10L) to mains.

The table below shows the values recommended for the fuses shown in the previous figure. They are slow general purpose fuses. If they are installed on the Mains input lines, their maximum currents will depend on the value of the Mains voltage.

Model	I _{peak}	Fuse
Units	A	A
ACSD-05L	05	04
ACSD-10L	10	08
ACSD-20L	20	16
ACSD-30L	30	25

Model	I _{peak}	Fuse
Units	A	A
ACSD-04H	04	04
ACSD-08H	08	08
ACSD-16H	16	16

NOTE. A thermal switch may optionally replace the fuses.

NOTE. The secondary windings must have a star connection with its middle point connected to ground.

Types of mains

Depending on the diagram of the electric energy distribution circuit, there are three types of mains: TN, TT and IT. Depending on the type of mains, the cabling in the electrical cabinet will vary considerably.

We here describe their characteristics and sample diagrams for a proper installation.

NOTE. Note that the diagrams do not show the main contactor that must be connected between the transformer or auto-transformer and the ACSD unit!

□ TN diagram

Distribution diagram that has a point directly connected to ground and the conductive parts of the installation are connected to this point through ground protection conductors. This type of mains admits loads between one or several phases and the neuter. There are three types of TN systems depending on the protection neuter and ground combination:

TN-S diagram where the neuter and the ground protection conductors are separated throughout the whole length of the system.

TN-C-S diagram where the neuter and the ground protection wire are combined in a single conductor somewhere in the system.

TN-C diagram where the neuter and the ground protection functions are combined in a single conductor throughout the system.



WARNING. TN type mains are the only ones to which the ACSD system can be connected either directly or through an auto-transformer.

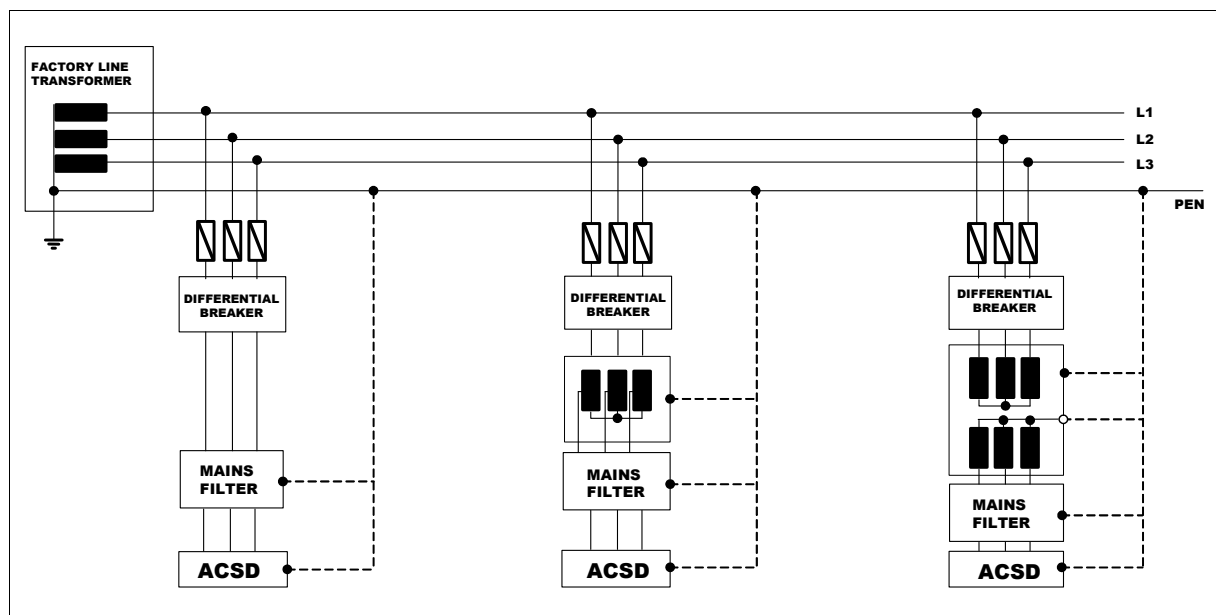

F. 21 TN diagram.

□ TT diagram

Distribution diagram that has a point directly connected to ground and the conductive parts of the installation are connected to this ground point independently from the ground electrode of the power supply system.

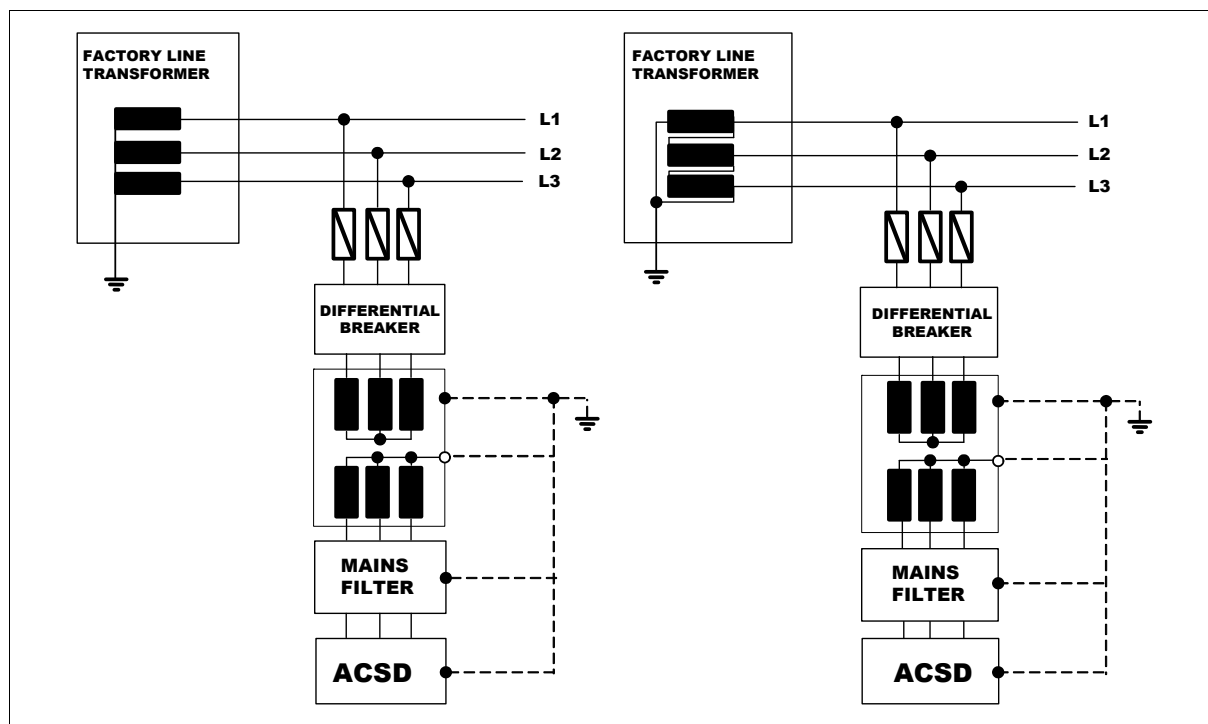

F. 22 TT diagram.

□ IT diagram

Distribution diagram that does not depend on any direct connection to ground and the conductive parts of the installation are connected to ground.

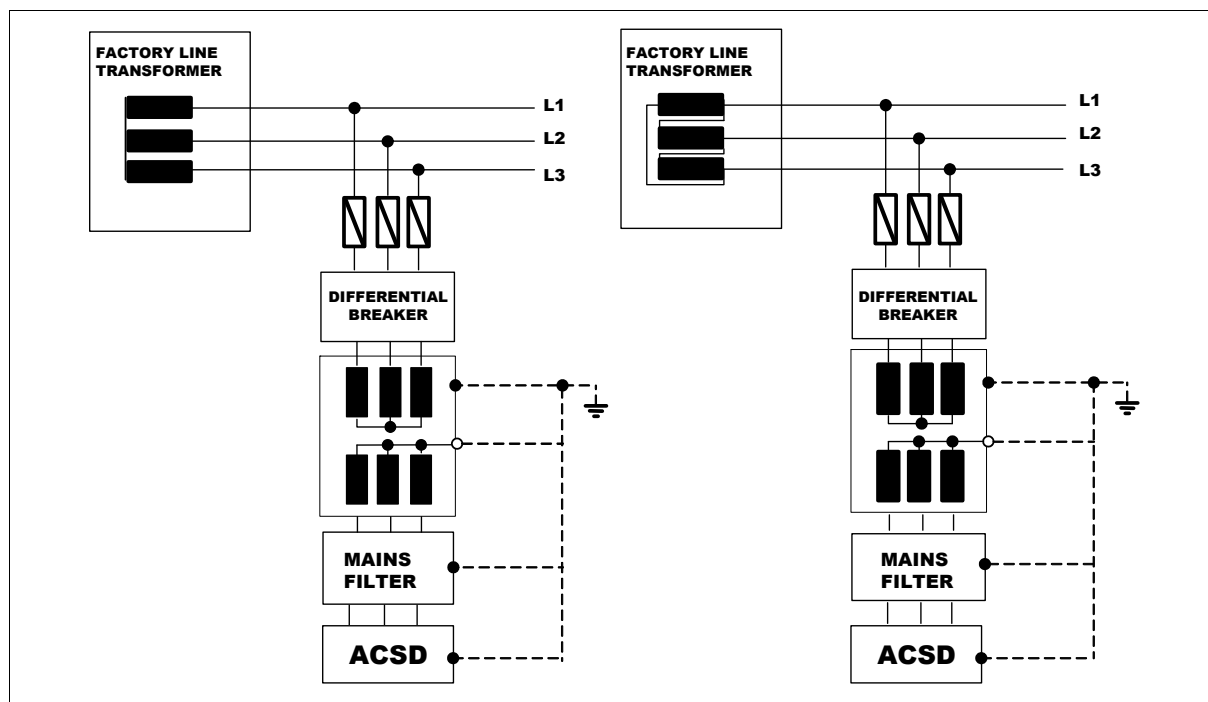

F. 23 IT diagram.

Power connection. Ballast resistor

If the application requires a Ballast resistor with more than 150 W:

- Remove the cable joining the terminals **Ri** and **L+**.
- Install the external resistor between the terminals **Re** and **L+**.
- Make sure that the resistance (Ohms) of the external ballast resistor is the same as that of the internal resistor of that module. See the table **General characteristics**.
- Use KV41 to indicate to the drive that an external ballast resistor has been connected.

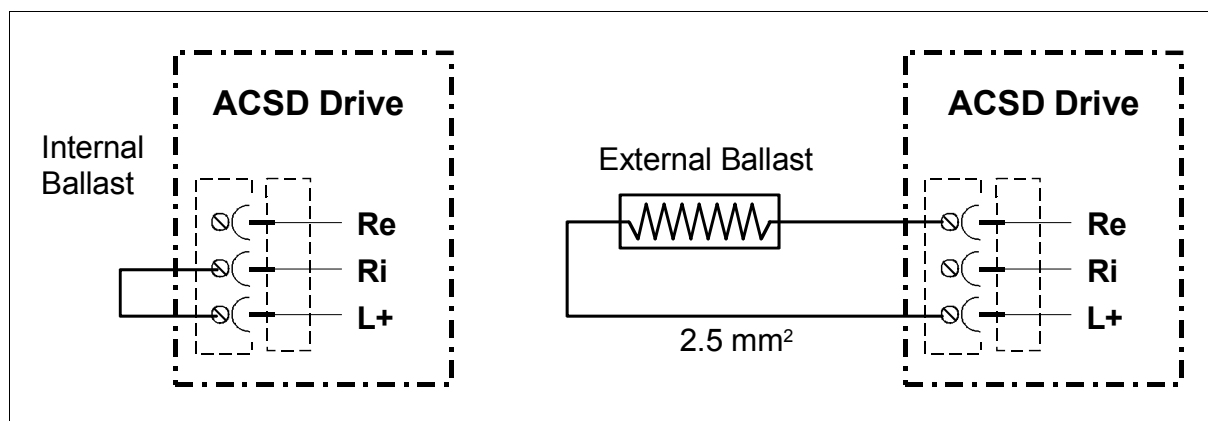

F. 24 Ballast resistor connection diagram.

Power connection. Drive - motor

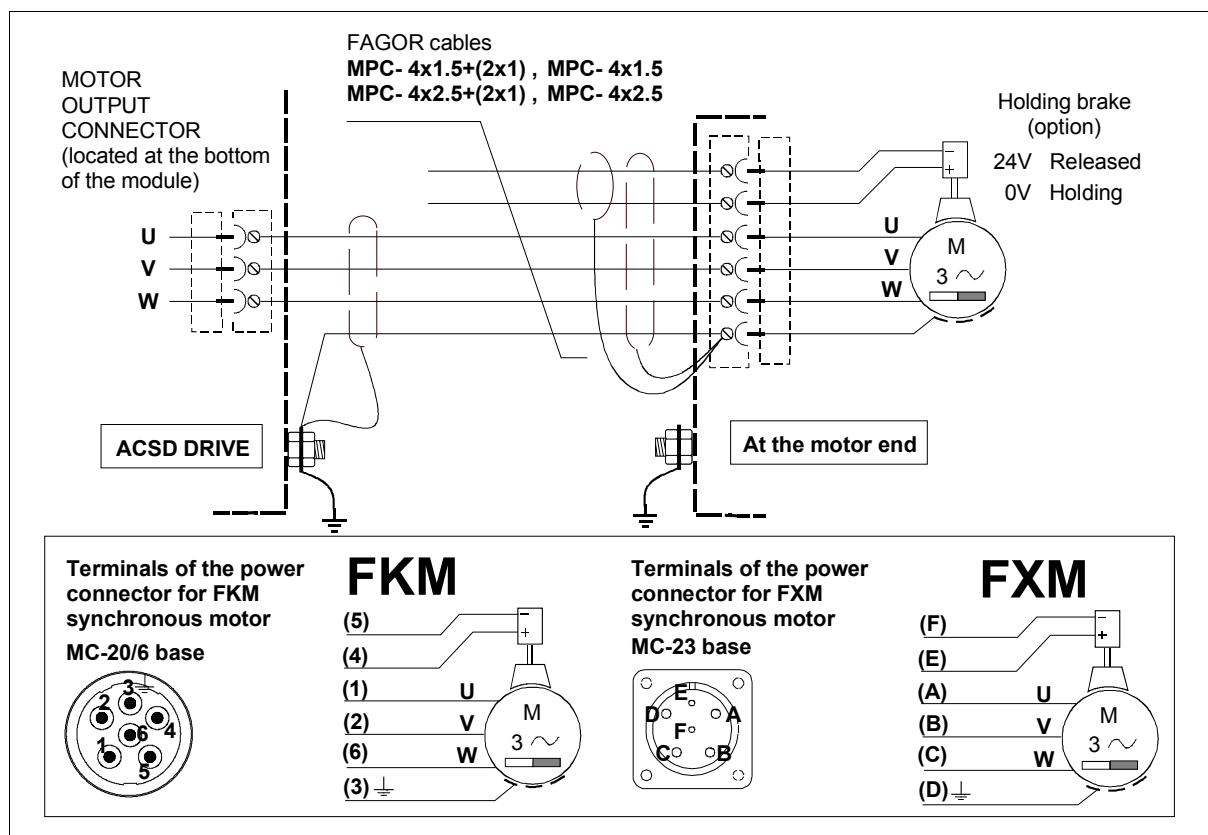

F. 25 Motor-drive power connection diagram.

Power cables

If the motor does not have a brake	If the motor has a brake
MPC-4x1.5	MPC-4x1.5+(2x1)
MPC-4x2.5	MPC-4x2.5+(2x1)

NOTE. The length of the MPC cable must be specifically ordered (in meters).

Codes of the **sales reference** of FAGOR power cables.

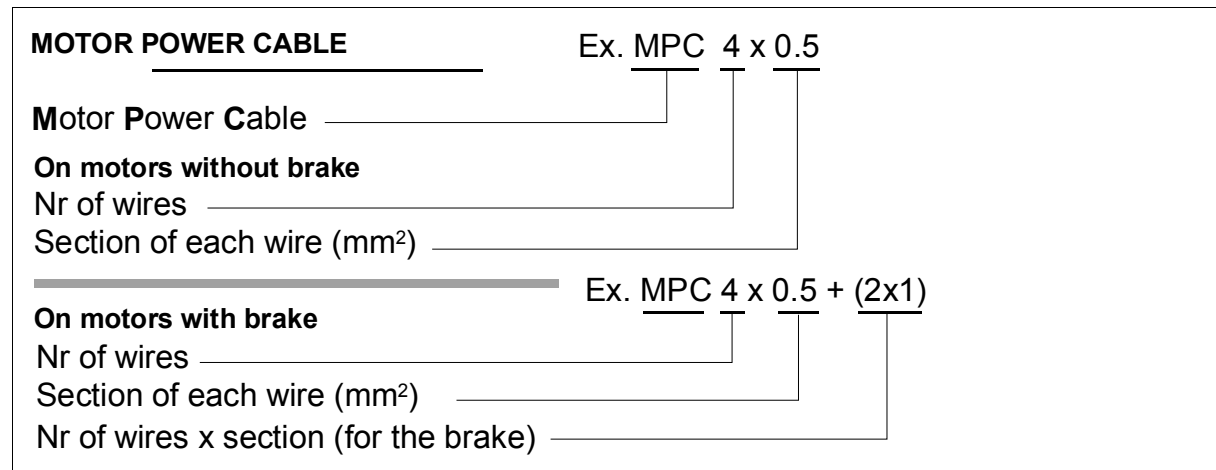

F. 26 Sales reference of the power cables.

Connection of the monitoring and control signals

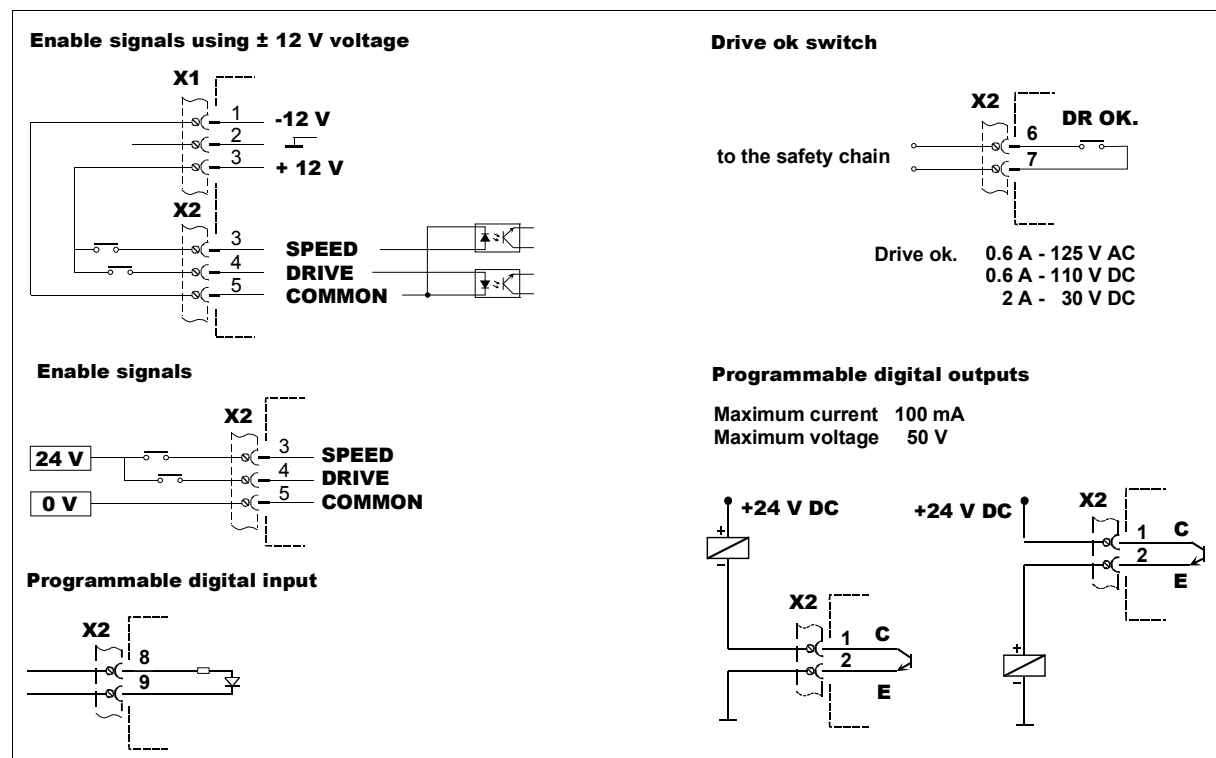

F. 27 Connection diagrams for monitoring and control signals.

Encoder feedback connection

The signals generated by the encoder are taken to the motor feedback Input of the ACSD drive. The encoder must be mounted on to the motor shaft and cannot be installed anywhere else in the transmission chain. The encoders that can be found on the motors depending on the series are:

At FXM servo motors	At FKM servo motors
I0. Incremental encoder 2500 ppt	I0. Incremental encoder 2500 ppt
E1. SinCoder encoder 1024 ppt	E3. SinCos taper shaft encoder 1024 ppt
A1. SinCos multi-turn encoder 1024 ppt	A3. SinCos multi-turn encoder 1024 ppt

Cables

FAGOR provides these full connections (cables + connectors): IECD, EEC-SP and CAN (without connectors).

TTL encoder connecting cable, IECD

The IECD cable transfers the motor feedback signals from the incremental TTL encoder (ref.I0) to the drive.

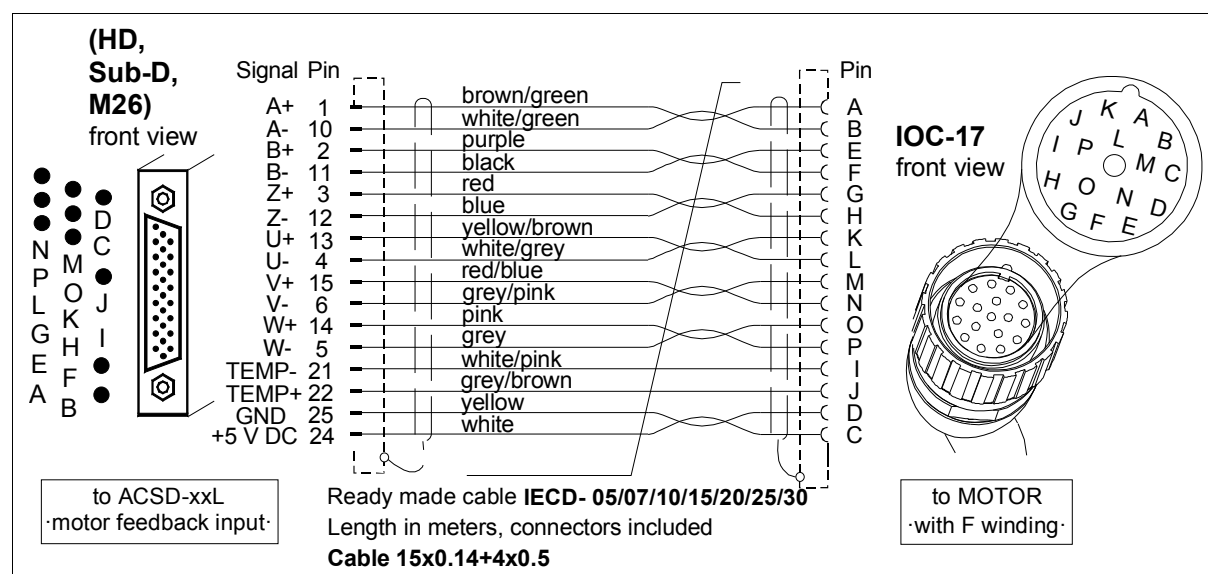

F. 28 Diagram of the IECD cable to connect the differential TTL encoder, ref. I0.

Sinusoidal encoder connecting cable, EEC-SP

The EEC-SP cable transfers the motor feedback signals from the sinusoidal encoder (ref. A1/A3/E1/E3) to the drive. It has overall shield and shielded twisted pairs.



INFORMATION. Note that type I and II of the EEC-SP extension cables shown next are the same except the color of some of their wires. The user must check which one matches the one being installed.

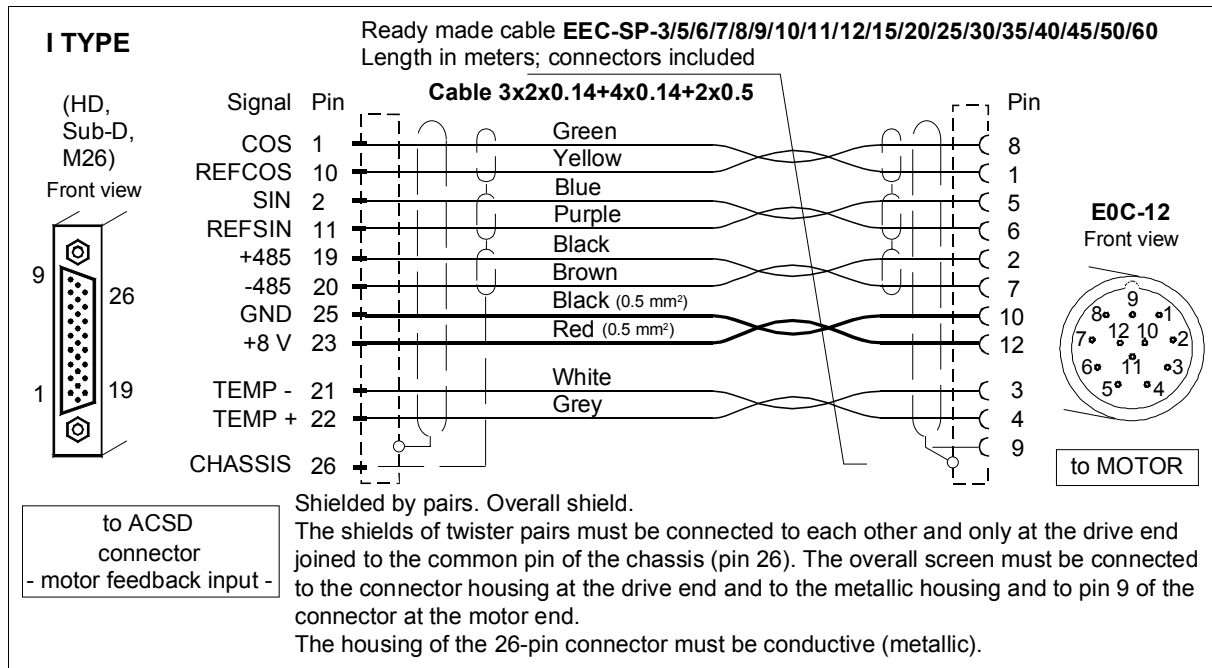

F. 29 Diagram for the sinusoidal encoder cable EEC-SP. Type I.

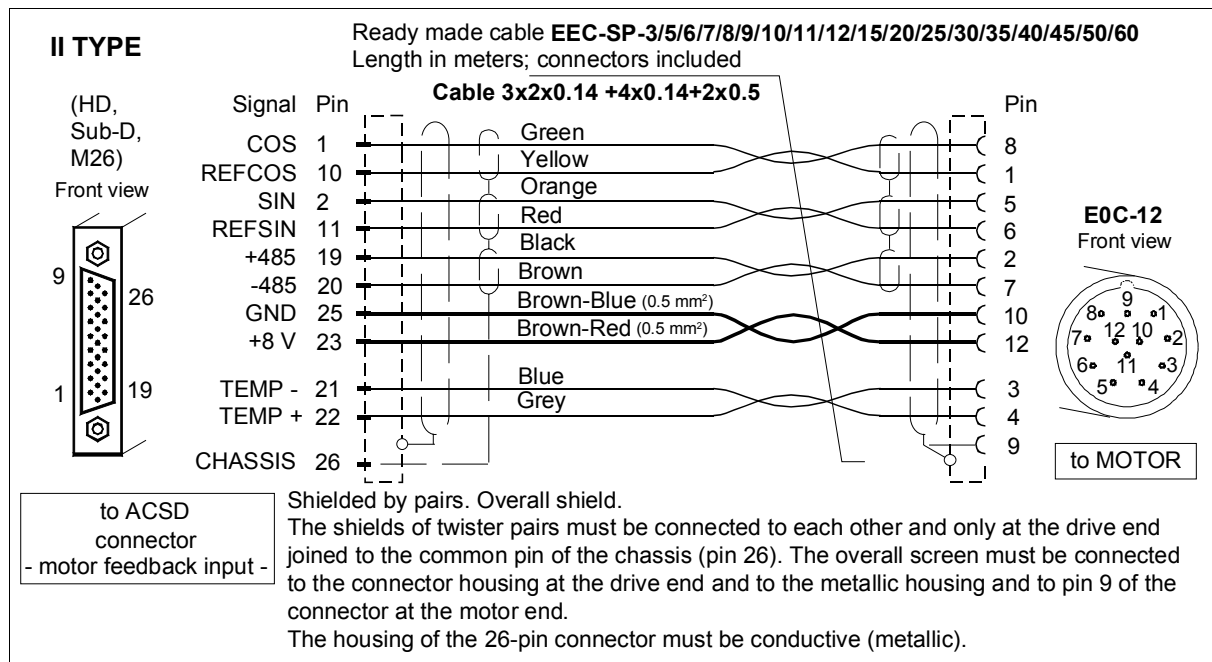

F. 30 Diagram for the sinusoidal encoder cable EEC-SP. Type II.

CAN field bus connection

The various ACSD modules and the device acting as MASTER are inter-connected through the CAN (X4) connector that incorporates each of these modules (see its front panel) using a specific CAN cable (twisted pairs with a section of 0.25 mm and an impedance of 120 Ω). They are connected in parallel and the elements at the ends connected to the bus must have the terminating resistor activated. The 16-position (0-15) rotary switch and the speed selector switch set the address occupied by each of the modules integrated in the CAN bus.

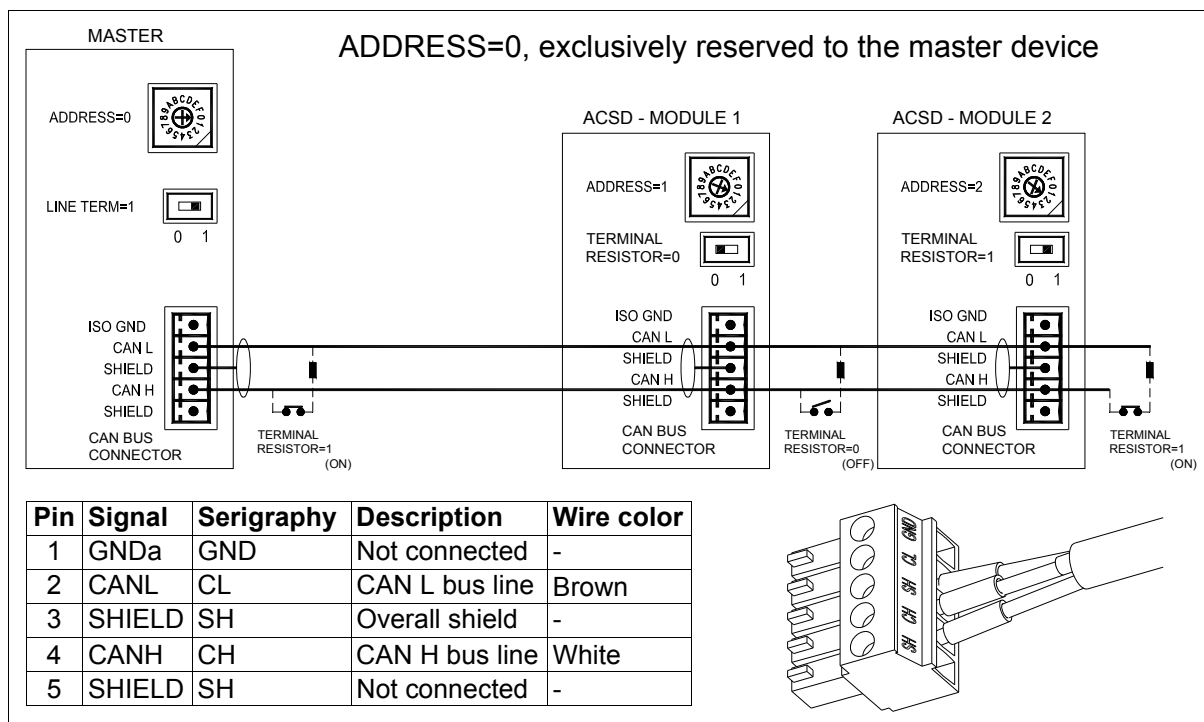

F. 31 Connection diagram for CAN communication bus.

CAN cable

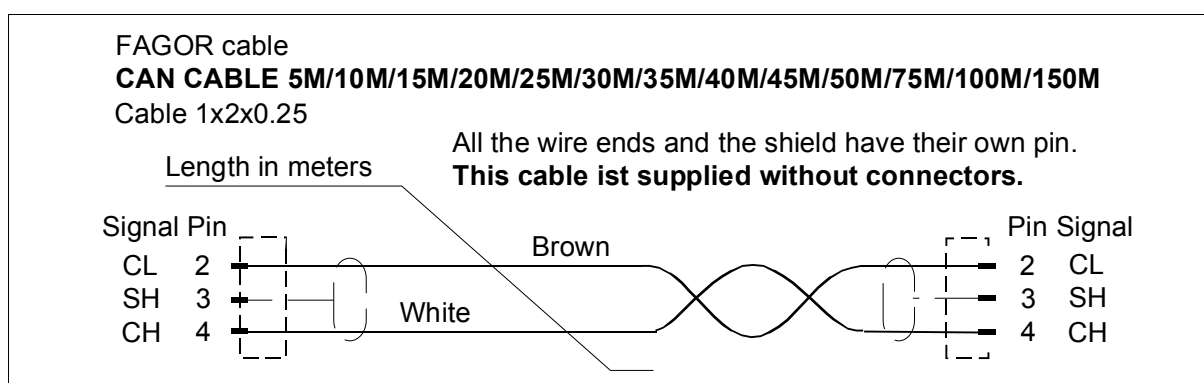

F. 32 Connection diagram of the cable for the CAN communication bus.

Codes of the FAGOR cables

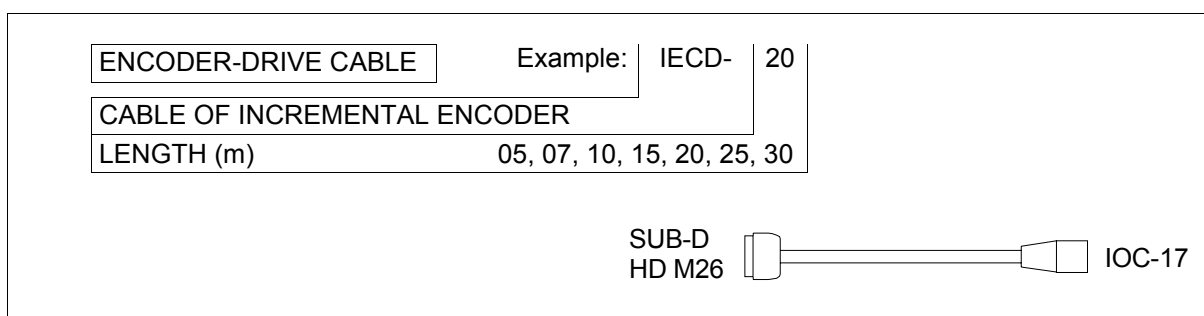

F. 33 Sales reference of the IECD cable.

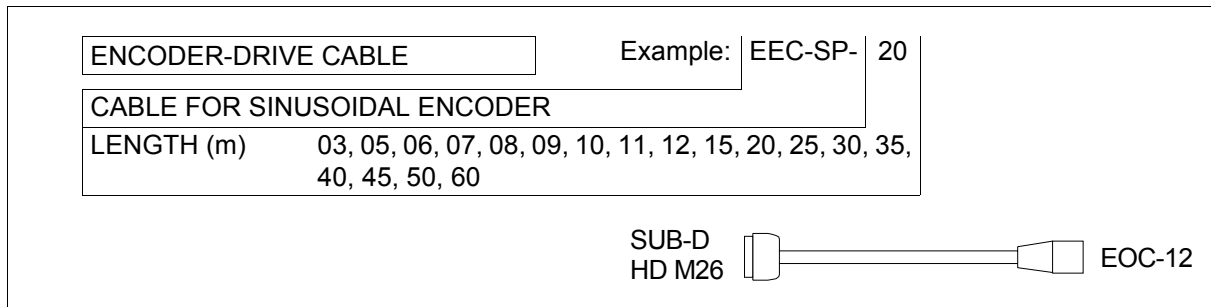

F. 34 Sales reference of the EEC-SP cable.

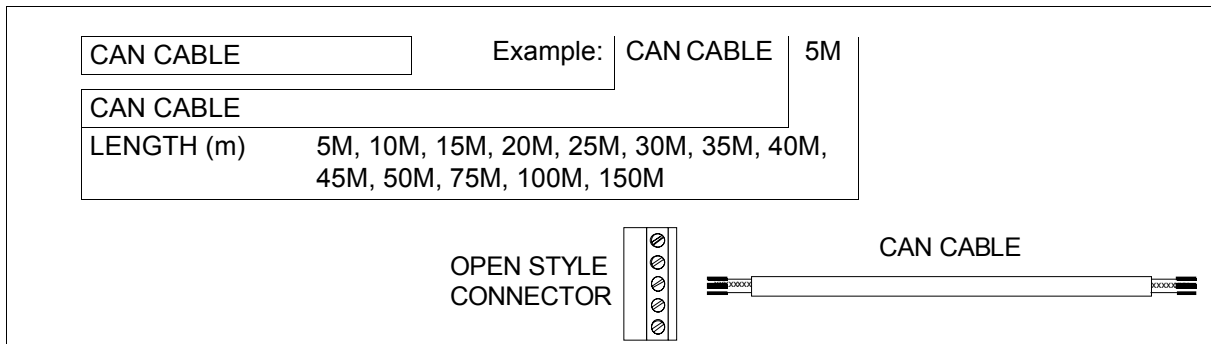

F. 35 Sales reference of the CAN cable.

Connecting a drive to a PC. RS-232 serial line

The ACSD drive will use this RS-232 line connection only for updating the firmware.

NOTE. It is not possible to set parameters, monitor variables of the system or adjust it through the RS-232 serial line.

The connection cable is:

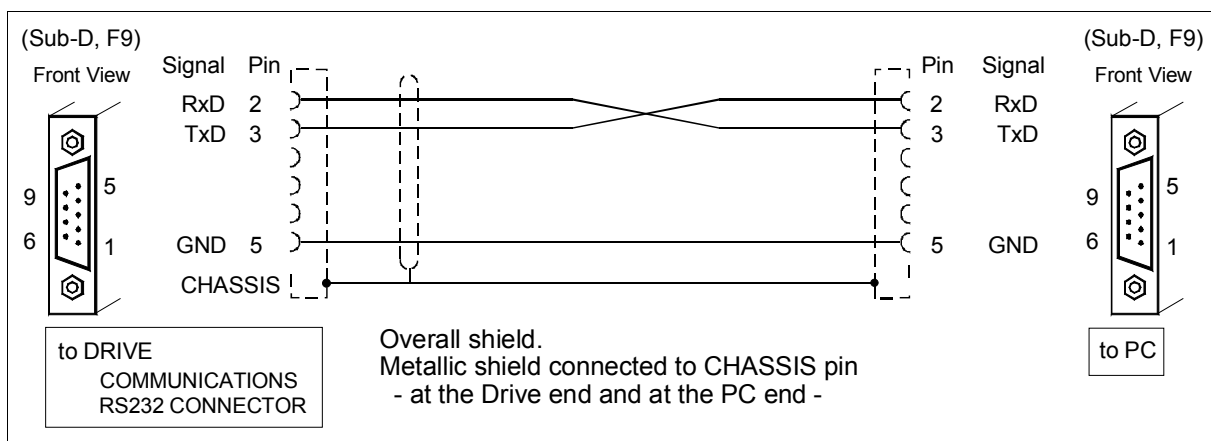

F. 36 RS-232 serial line connection diagram.

Diagram of the electrical cabinet

This is an orientative diagram for the installation of the electrical cabinet. This diagram may be modified according to the requirements of each application.

It includes a simple circuit for the voltage supply of the brake of the servo motors.

NOTE. When installing a transformer, the secondary must have a star connection and its middle point must be connected to ground.

NOTE. The use of fuses is a must.

Mains connection and maneuver diagram

The delayed disconnection of KA3 contacts is useful so:

- The Drive_Enable stays active while the motor brakes at maximum torque.
- The brake holds the motor after it has stopped.

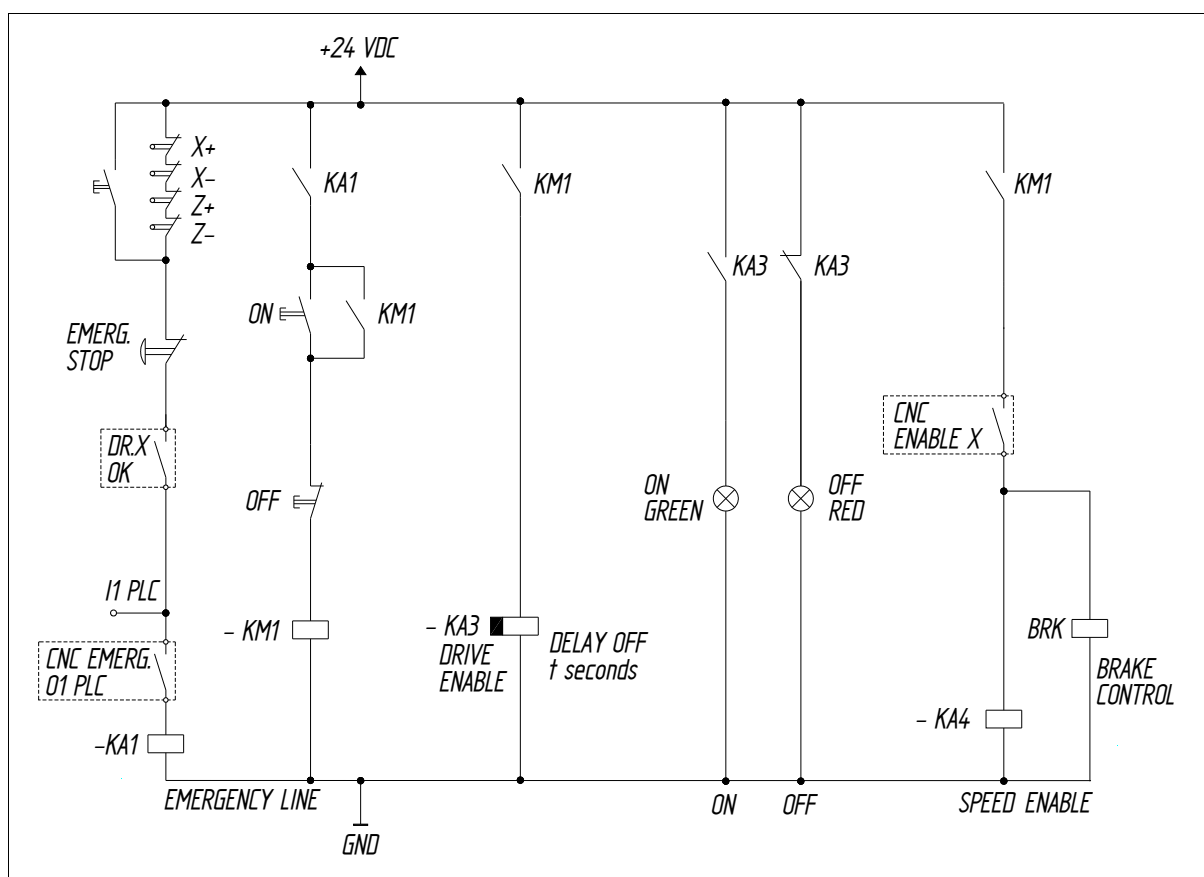

F. 37 Illustrative connection diagram of the electrical cabinet.

Initialization and adjustment

The system can only be initialized and adjusted using the CAN field bus (communication interface included in the ACSD drive). This process is carried out from the master device (CNC).

NOTE. Remember that the serial line can only be used to download the software to the drive.



WARNING. To update the software version of the ACSD drive, the CNC must be disconnected. If this condition is not met, the user must reset it with a **<SHIFT+RESET>** once the software has been loaded.

Initially, bear in mind the elements that make up each drive in order to configure the communication with the master device. These elements are:

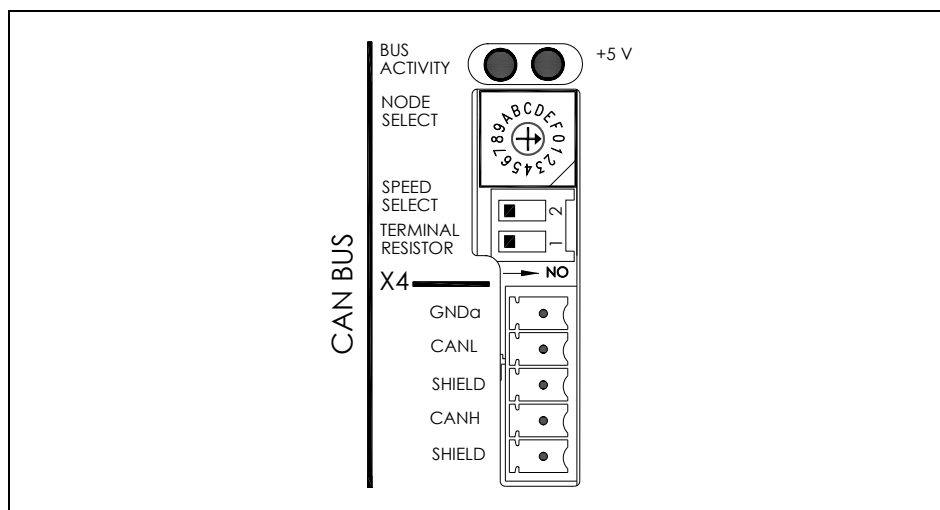

TERMINAL RESISTOR. Terminating resistor

Before starting up the system, the last drive connected to the bus will be the farthest away from the master device and must be the only whose terminating resistor is activated (ON). The rest of the drives must have it turned OFF.

See figure of section - **CAN field bus connection** -

NODE SELECT. Node selector

Rotary selector that together with the **SPEED SELECT** switch is used to determine the node number assigned to the drive in the CAN bus. The node number must be selected before starting up the drive, otherwise it will only be valid after restarting and resetting the drive again. The protocol does not accept the “0” node; therefore, selecting it implies going into the “bus speed selection” sequence.

SPEED SELECT

Selector that can help the **NODE SELECT** select the node number and can confirm the communication speed of the CAN bus.

How to select the bus speed?

Proceed as follows to select the bus speed:

- Start the drive up (or do a reset) with the rotary switch in the “0” position.
- The **BUS ACTIVITY** indicating LED will blink twice quickly (50 ms on) in 1 second intervals.
- Now, select the transmission speed with the node selecting rotary switch.
- The selected speed will be effective when setting the **SPEED SELECT** selector to ON. This speed is immediately saved in the drive's E²PROM memory. The LED stops blinking and stays on and the drive stays in the “non-operative” state indefinitely.

NOTE. Do not forget to set the **SPEED SELECT** back OFF.

- Now select the node number (attending to the status **SPEED SELECT** selector) and reset the unit to start it up properly.

Node Select	Transmission speed (rate)
0	1 MBd
1	800 kBd
2	500 kBd
3	250 kBd
4	125 kBd

Node Select	Transmission speed (rate)
5	100 kBd
6	50 kBd
7	20 kBd
8	10 kBd
others	1 MBd

NOTE. Note that if the drive is started up with the **NODE SELECT** switch in the 0 position, and the **SPEED SELECT**, the previous sequence is executed immediately hence selecting a CAN speed of 1 MBd.

How to select the node number?

The node number is set with the combination of the **NODE SELECT (NS)** switch and the **SPEED SELECT (SS)** switch according to the following formula:

$$\text{Node} = \text{NS} + (16 \times \text{SS}) \quad \text{where NS can never be 0}$$

Examples.

To assign node number 13 to a drive, the SS selector must be in the OFF position and the rotary selector NS in the D position (13 in decimal), which results from the previous formula the node value:

$$\text{Node} = 13 + (16 \times 0) = 13$$

To assign node number 20 to a drive, the SS switch must be in the ON position and the rotary selector NS in the 4 position, which results from the formula the node value:

$$\text{Node} = 4 + (16 \times 1) = 20$$

NOTE. Note that to select the node number between 1 and 15, the SPEED SELECT switch must be in the OFF position.

The following diagrams shows the mentioned situations:

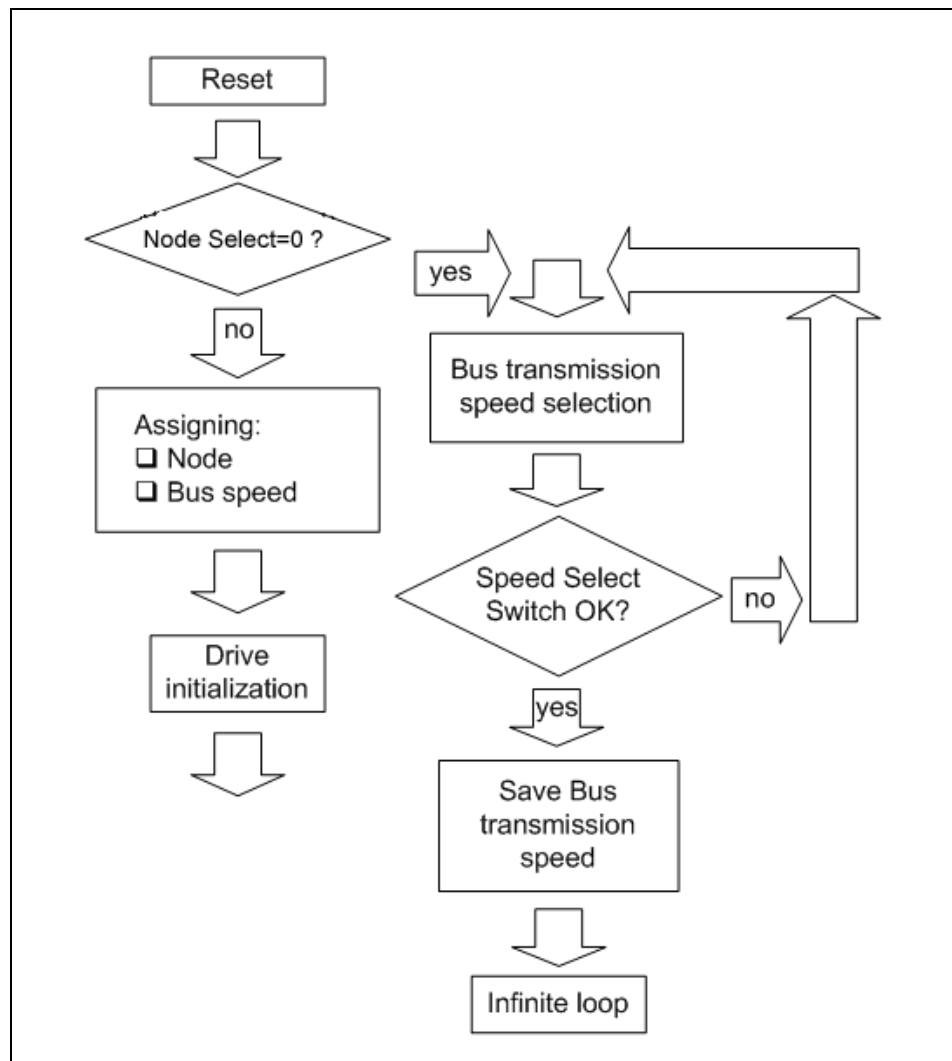

All of the possibilities for displaying and modifying parameters, variables and commands can only be accessed from the master device and their availability depends on a particular access level.

BUS ACTIVITY. This LED is the only element that, without a master CAN device, allows displaying the status of the unit. This indicator light informs of the status of the CAN bus and the status of the drive.

The following table shows the different situations of the indicator light and their meanings.

Status	Meaning
OFF	No bus The bus is being initialized or has not been able to start up. Drive without errors.
ON	Running The bus is working with all its features and allows enabling the unit.
Slow blinking 200 ms ON 200 ms OFF	Pre-running The bus is in the parameter setting stage (asynchronous) and does not allow to enable the drive.
Fast blinking 50 ms ON 50 ms OFF	Error The drive is in an error state.
Double flash 50 ms ON/OFF 1 s OFF	Speed selection The drive has started up with the NODE SELECT switch in "0" and it is in the speed selection stage.

NOTE. A drive puts out pulses only if the BUS ACTIVITY indicator is lit, power is applied to it, the hardware enables are activated and the CNC enables it through the CAN bus.

PARAMETERS, VARIABLES & COMMANDS

The parameters, variables and commands of the drive that are shown next may be used with any device that works as master. Besides all these, there are others that may be used to communicate the drive with the CNC.

Notation

<Group> <Type> <Index> where:

Group. Identifying character of the logic group to which the parameter or variable belongs.

There are the following groups of parameters:

Nr	Function	Group	Letter
1	Control signals	Terminal box	B
2	Current control loop	Current	C
3	Error diagnosis	Diagnosis	D
4	General of the system	General	G
5	System hardware	Hardware	H
6	Analog and digital inputs	Inputs	I
7	Temperatures and voltages	Monitoring	K
8	Motor properties	Motor	M
9	Linear configuration	Linear axis	N
10	Analog and digital outputs	Outputs	O
11	Position loop	Position	P
12	System communication	Communication	Q
13	Rotor sensor properties	Rotor	R
14	Velocity control loop	Speed	S
15	Torque and power	Torque	T

Type. Character identifying the type of data which the information corresponds to. May be:

- Parameter (P) defining the system operation
- Variable (V) that can be read and modified dynamically
- Command (C) that carries out a specific action

Index. Character identifying the parameter or the variable within the group to which it belongs.

Definition examples:

SP10: S group, (P) Parameter, (Nr) 10.

CV11: C group, (V) Variable, (Nr) 11.

GC1: G group, (C) Commando, (Nr) 1.

Access level. The access level is defined by the number following the ID. Hence:

- FAGOR level - 1 -
- User level - 2 -
- Basic level - 3 -

Examples of access levels:

SP10 basic: Group **S**, (P) Parameter, (Nr) 10, access level (basic)
CV11 Fagor, RO:Group **C**, (V) Variable, (Nr) 11, (Fagor) access level, read-only variable (RO).

Modifiable variable. Any modifiable variable, in other words, that can be read and written, will carry the (RW) label to identify it as such next to its access level. The (RO) label means that the variable is Read Only.

Note that all the parameters have the (RW), i.e. they can be read and written.

Example of a modifiable variable:

DV32 Fagor, RW: D Group, (V) Variable, (Nr) 32, (Fagor) Access level, (RW) modifiable.

Parameter that cannot be modified with torque. Any parameter that for any reason cannot be modified while the unit has torque will have an asterisk (*) identifying it as such next to its access level.

Example of a parameter that cannot be modified with torque:

MP1 Basic, *RW: Group M, (P) Parameter, (Nr) 1, (basic) access level, (*) not modifiable with torque, (RW) parameter (read and write).

Groups

B. Non-programmable inputs and outputs

BV14	FAGOR, RO	S32972	NotProgrammableIOs
------	-----------	--------	--------------------

Function Indicates the logic values of the electrical signals of the drive's control. 24 V at the electrical input mean a logic 1 at the bits of this variable.

Bit Nr	Function
15 ... 4	Reserved
3	Programmable input Pins 8 -9 of terminal strip X2 Default value (IP14=4), error RESET.
2	Drive_OK output Pins 6 -7 of terminal strip X2
1	Speed_Enable input Pin 3 of terminal strip X2
0	Drive_Enable input Pin 4 of terminal strip X2

C. Current

CP1	*FAGOR, RW	S00106	CurrentProportionalGain
-----	------------	--------	-------------------------

Function Value of the proportional action of the current PI.

Valid values 0 ... 999.

Default value Depends on the motor-drive combination.

CP2	*FAGOR, RW	S00107	CurrentIntegralTime
-----	------------	--------	---------------------

Function Value of the integral action of the current PI.

Valid values 0 ... 999.

Default value Depends on the motor-drive combination.

CP20	*BASIC, RW	S33075	CurrentLimit
------	------------	--------	--------------

Function Limit of the current command that reaches the system's current loop.

Valid values 0.00 ... 50.00 Arms. CP20 must never exceed the smallest value given by the peak current of the motor (5 x MP3) and of the drive.

Default value CP20 takes the lowest value of the ones given by the motor and drive peak currents.

CP30	FAGOR, RW	S33076	CurrentCommandFilter1Type
------	-----------	--------	---------------------------

Function Parameter in charge of disabling/enabling the current filter.

Valid values 0/1 Disable/Enable.

Default value 0 Disable.

CP31	FAGOR, RW	S33080	CurrentCommandFilter1Frequency
------	-----------	--------	--------------------------------

Function Sets the natural frequency in Hz of a notch filter that acts upon the current command.

Valid values 0 ... 4000 Hz.

Default value 0.

CP32	FAGOR, RW	S33081	CurrentCommandFilter1Damping
------	-----------	--------	------------------------------

Function Sets the bandwidth in Hz of a notch filter that acts upon the current command.

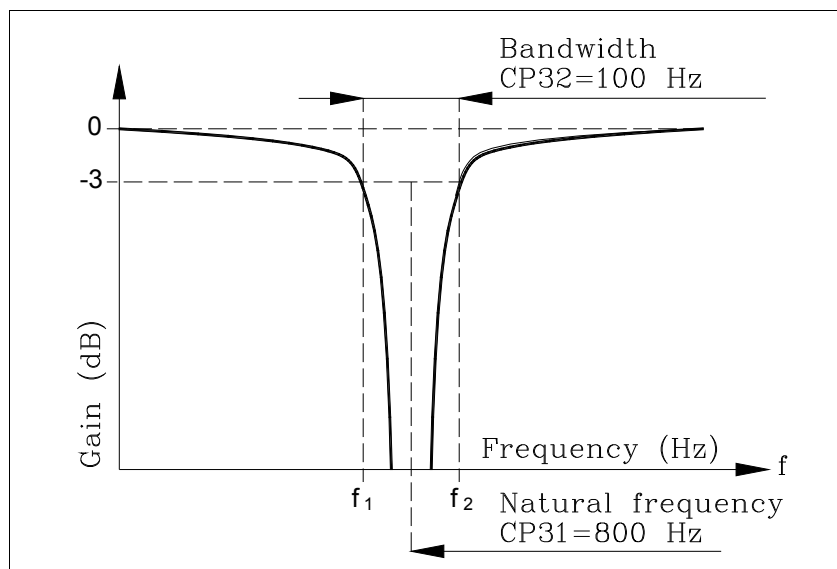

Valid values 0 ... 1000 Hz.

Default value 0.

CV1	USER, RO	S33077	Current1Feedback
-----	----------	--------	------------------

Function Display the value of the feedback of the current going through phase V.

Valid values - 50.00 ... 50.00 A (instant values).

CV2	USER, RO	S33078	Current2Feedback
-----	----------	--------	------------------

Function Display the value of the feedback of the current going through phase W.

Valid values - 50.00 ... 50.00 A (instant values)

CV3	USER, RO	S33079	CurrentFeedback
-----	----------	--------	-----------------

Function Display the rms current circulating through the motor.

Valid values - 50.00 ... 50.00 Arms (rms value).

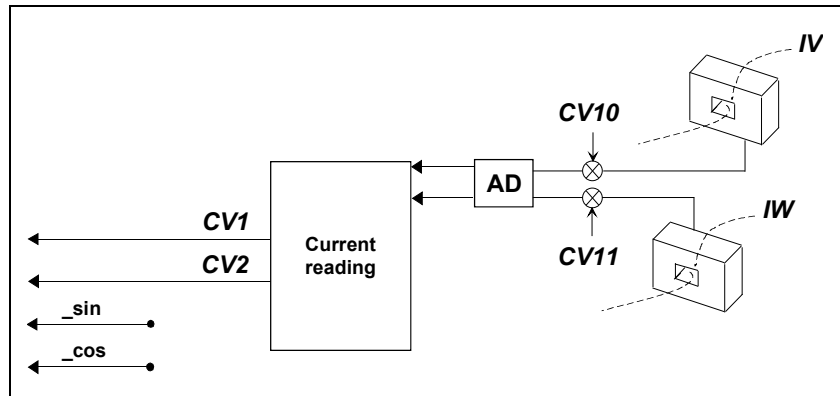

CV10	FAGOR, RO	S33073	Current1Offset
------	-----------	--------	----------------

Function Value of the automatic compensation of the current feedback offset of phase V.

Valid values - 2.000 ... 2.000 A (depends on the drive connected).

CV11	FAGOR, RO	S33074	Current2Offset
------	-----------	--------	----------------

Function Value of the automatic compensation of the current feedback offset of phase W.

Valid values - 2.000 ... 2.000 A (depends on the drive connected).

D. Diagnosis

DV17	USER, RO	S33178	HistoricOfErrors
------	----------	--------	------------------

Function Stores the last 5 errors that came up at the drive. It is a 5-word register that stores the numbers of the last 5 errors originated at the drive.

Valid values All the numbers of the possible errors of the software version loaded. Code 0 means no error.

DV31	FAGOR, RO	S00135	DriverStatusWord
------	-----------	--------	------------------

Function This variable contains a numerical data coded into 16 binary bits and represents the system status as shown by the attached table. Bits (from the most to the least significant).

Bit Nr	Function
15, 14	Power & Torque Status 0,0 DoingInternalTest DRVSTS_INITIALIZATING 0,1 ReadyForPower DRVSTS_LBUS 1,0 PowerOn DRSTS_POWER_ON 1,1 TorqueOn DRSTS_TORQUE_ON
13	Error bit

12	Warning
11	OperationStatusChangeBit
10	WarningMainsLine
9 ... 7	Reserved
6	ReferenceMarkerPulseRegistered
5	ChangeCommandsBit
4 ... 1	Reserved
0	DriveStatusWordToggleBit

Version Modified in version 02.04. Bit 10 has been added.

DV32	FAGOR, RW	S00134	MasterControlWord
------	-----------	--------	-------------------

Function This variable contains a numerical data coded into 16 binary bits and represents the control signals that act upon the drive through the serial line. Bits (from the most to the least significant).

Bit Nr	Function
15	Speed Enable
14	Drive Enable
13	MainsLineFaultBehaviour In the event of a missing phase or low voltage on the power bus: = 0 E.003 or E.307 and dynamic braking. = 1 E.003 or E.307 after a prior WarningMain- sLine, DV31. bit 10 warning sent two se- conds earlier to the CNC.
12 ... 7	Reserved
6	Homing Enable
5 ... 1	Reserved
0	MasterControlWordToggleBit

Version Modified in version 02.04. Bit 13 has been added.

DC1	USER, RW	S00099	ResetClassDiagnostics
-----	----------	--------	-----------------------

Function Reset of the unit's errors. When an error occurs, this command may be used to reset it and restart the unit by first updating the error bit of DV31, DriveStatusWord, and then setting the drive in the ReadyForPower state. Note its difference with the unit's reset because the action carried out by this command keeps the RAM memory intact and therefore the parameter settings of the unit.

DC2	USER, RW	S33170	ClearHistoricOfErrorsCommand
-----	----------	--------	------------------------------

Function Reset of the DV17 variable HistoricOfErrors (array). This command sets it to 0.

G. General

GP3	BASIC, RW	S33470	StoppingTimeout
-----	-----------	--------	-----------------

Function After deactivating the Speed_Enable and after the GP3 time has elapsed, if the motor has not stopped, it cancels the torque automatically and issues error E.004. If the motor stops within the GP3 time, it also cancels the torque but does not issue an error. To make this time infinite (never generating error E.004), set this parameter to "0".

Valid values 1 ... 9999 ms, 0 (infinite).

Default value 500 ms.

GP5	BASIC, RO	S33468	ParameterVersion
-----	-----------	--------	------------------

Function This parameter represents the version of the parameter table that has been loaded at the drive.

GP9	BASIC, RW	S00207	DriveOffDelayTime
-----	-----------	--------	-------------------

Function After the motor has stopped because the Speed Enable function has been disabled, the cancellation of the Drive Enable (that implies PWM-OFF) is delayed by a time period indicated by GP9. It is useful on axes not compensated with a holding brake. To make this time period infinite, set it to 0 and to remove it, set it to 1.

Valid values 1 ... 9999 ms, 0 (infinite).

Default value 50 ms.

GP15	FAGOR, RW	S33494	AutomaticInitialization
------	-----------	--------	-------------------------

Function When having a SinCos or SinCoder encoder it enables reading MP1 directly from the sensor and consequently loading certain drive parameter automatically.

If GP15 = 0, it does not check the format of MP1.

Valid values 0/1 Disabled/enabled (by default).

GP16	BASIC, RW	S33495	MonoPhaseSelector
------	-----------	--------	-------------------

Function It enables or disables the option to feed ACSD-xxL (220 V AC) with single-phase power voltage without activating the error code for missing phase. Keep in mind that on 20 A and 30 A drives, the software will limit the current internally to 10 A.

NOTE. Not being used on ACSD-xxH (400 V AC) units. The bus voltage will not be reached when feeding these units with single-phase voltage.

Valid values 0/1 Disabled (by default)/enabled.

GV2	BASIC, RO	S00030	ManufacturerVersion
-----	-----------	--------	---------------------

Function Displays the software version in use.

GV5	BASIC, RO	S33474	CodeChecksum
-----	-----------	--------	--------------

Function It registers the checksum value of the software version loaded at the drive.

Valid values - 32 768 ... 32 767 (although the range goes up to 65535 because it is a 16-bit variable). The programming module can only display the 4 least significant digits. E.g. If GV5=47 234, the display of the programming module shows 7234.

GV7	BASIC, RW	S00267	Password
-----	-----------	--------	----------

Function Variable where the password is entered to change the access level. The system will change the access level corresponding to the password entered.

Valid values 0 ... 9999.

GV9	BASIC, RO	S00140	DriveType
-----	-----------	--------	-----------

Function This variable informs of the drive's sales reference.

GV11	BASIC, RW	S33476	SoftReset
------	-----------	--------	-----------

Function Variable that resets the unit by software.

Valid values 0 and 1 (with 1, it resets the unit).

GV16	BASIC, RO	S33484	MotorTableVersion
------	-----------	--------	-------------------

Function Version of the motor table.

GV75	FAGOR, RO	S00375	ErrorList
------	-----------	--------	-----------

Function List of the error numbers active in the unit.

Valid values - 32 768 ... 32 767.

GC1	*BASIC, RW	S00264	BackupWorkingMemoryCommand
-----	------------	--------	----------------------------

Function Command to execute the parameter transfer from RAM to E²PROM.

GC3	FAGOR, RW	S33498	AutophasingCommand
-----	-----------	--------	--------------------

Function Command that lets activate the Autophasing sequence.

Procedure to follow:

- Connect the drive to the motor with the SinCos or SinCoder installed (power and feedback cables) and without a load on the shaft.
- Apply control voltage and power.
- Enable the Drive_Enable input of the drive (pin 4 of X2) and disable the Speed_Enable input (pin 3 of X2).

- Execute GC3.

The motor will start positioning and it will be completed after about 30 or 40 seconds. At this instant, the new Rho has been calculated. Its value may be displayed in the RV3 variable.

- Select MP1 and edit the motor type.
- Select RC1 and execute it to save the new values of RV3 and MP1 in the E²Prom of the encoder.

GC10	*BASIC, RW	S00262	LoadDefaultsCommand
------	------------	--------	---------------------

Function Command to initialize parameters. It loads the default drive parameters, by default, for a motor that has been previously selected with parameter MP1.

H. Hardware

HV5	BASIC, RO	S33063	PLDVersion
-----	-----------	--------	------------

Function Software version installed in the unit's PLD's.

I. Inputs

IP6	USER, RW	S33678	DigitalInputPolarity
-----	----------	--------	----------------------

Function Sets the polarity (inverted or not inverted) of the digital input (pins 8 and 9 of X2).

Valid values 0/1 Not inverted/inverted.

Default value 0 Not inverted.

IV10	USER, RO	S33675	DigitalInputs
------	----------	--------	---------------

Function This variable reflects the status of the digital input at pins 8 - 9 of connector X2. The status of this variable is affected by IP6.

Valid values 0 (by default) and 1.

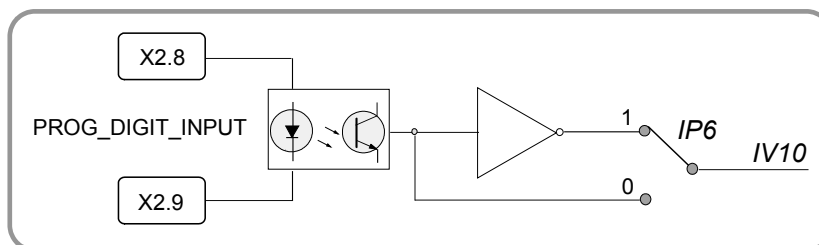

K. Monitoring

KP3	USER, RW	S33882	ExtBallastPower
-----	----------	--------	-----------------

Function Contains the value of power of the external ballast resistor.

Valid values 200 ... 2 000 W.

Default value 200 W.

KP4	USER, RW	S33884	ExtBallastEnergyPulse
-----	----------	--------	-----------------------

Function Contains the value of the energy pulse that can be dissipated by the external ballast resistor.

Valid values 200 ... 2 000 J.

Default value 200 J.

KV6	BASIC, RO	S00383	MotorTemperature
-----	-----------	--------	------------------

Function Motor temperature in degrees centigrade (for the time being, it is now only valid for the FKM family).

Valid values 0 ... 200 °C.

KV10	USER, RO	S33870	CoolingTemperature
------	----------	--------	--------------------

Function It displays the temperature of the heatsink of the power stage.

Valid values 0 ... 200 °C.

KV32	USER, RO	S33877	I2tDrive
------	----------	--------	----------

Function Variable internally useful to the system. It measures the internal load level of the calculation of the i^2t at the drive in percentage used over the maximum.

Valid values 0 ... 100 %.

KV36	USER, RO	S33879	I2tMotor
------	----------	--------	----------

Function Variable internally useful to the system. It measures the internal load level of the calculation of the i^2t at the motor in percentage used over the maximum.

Valid values 0 ... 100 %.

KV40	USER, RO	S33883	I2tCrowbar
------	----------	--------	------------

Function Shows the load percentage on the ballast resistor in a drive. Useful for the i^2t protection of the resistor. A value greater than 100 % in this variable causes error E.314.

Valid values 0 ... 100 %.

KV41	USER, RW	S33885	BallastSelect
------	----------	--------	---------------

Function Selector that determines whether the Ballast resistor is external or internal.

Valid values 0/1 External/internal.

M. Motor

MP1	*BASIC, RW	S00141	MotorType
-----	------------	--------	-----------

Function motor identification. The limits of certain parameters depend on the value of MP1 (for example: The upper limit of SP10 is 110 % of the motor rated speed) like its default parameter initialization through GC10. See command GC10.

MP2	*FAGOR, RW	S33968	MotorTorqueConstant
-----	------------	--------	---------------------

Function Contains the torque constant of the synchronous motor; i.e. the motor torque according to the rms current.

Valid values 0.00 ... 10.00 N·m/Arms

Default value 10.00 N·m/Arms.

MP3	*FAGOR, RW	S00111	MotorContinuousStallCurrent
-----	------------	--------	-----------------------------

Function Contains the motor rated current. Manipulating MP3 may affect parameter CP20 directly. See parameter CP20.

Valid values 0.00 ... 50.00 Arms. Depends on the motor connected.

Default value 10.00 Arms.

MP24	*FAGOR, RW	S33988	MotorMomentumOfInertia
------	------------	--------	------------------------

Function Motor inertia.

Valid values 0.1 ... 1 000.0 kg·cm².

Default value It depends on the motor connected.

NOTE. This parameter will be set to its default value on power-up whenever GP15 has been set to "1".

N. Linear axis configuration

NP1	USER, RW	S34968	LoadMomentumOfInertiaPercentage
-----	----------	--------	---------------------------------

Function Parameter that shows the relationship between the load inertia and that of the motor rotor. When calculating this ratio, bear in mind the mechanical transmission ratio between the load movement and the motor rotation.

Valid values 0.00 ... 1 000.00 %.

Default value 0.00 %.

NP116	FAGOR, RO	S00116	ResolutionOfFeedback1
-------	-----------	--------	-----------------------

Function Parameter that cannot be modified by the user that “tells” the CNC the number of pulses of the motor feedback.

Valid values 0 ... 65 535 pulses.

Default value It depends on the motor connected.

NP121	FAGOR, RW	S00121	InputRevolutions
-------	-----------	--------	------------------

NP122	FAGOR, RW	S00122	OutputRevolutions
-------	-----------	--------	-------------------

Function They define the gear ratio between the motor shaft and the final axis moved by the machine. For example, if 5 turns of the motor shaft mean 3 turns of the machine leadscrew, the value of these parameters is NP121=5, NP122=3.

Valid values 1 ... 65 535 turns.

Default value 1 turn in both parameters (direct coupling).

NP123	FAGOR, RW	S00123	FeedConstant
-------	-----------	--------	--------------

Function It defines the gear ratio between the linear movement of the machine and the axis moving it. For example, if every turn of the leadscrew means a 4 mm displacement of the table, the value for this parameter is NP123=4. If it is a rotary axis, set NP123 = 360 (360° per turn).

Valid values 0 ... 214 748 mm.

Default value 5 000 µm (5mm per turn).

O. Analog and digital outputs

OP6	USER, RW	S34184	DigitalOutputPolarity
-----	----------	--------	-----------------------

Function Sets the polarity (inverted or not inverted) of the digital output (pins 1 and 2 of X2).

Valid values 0/1 Not inverted/inverted

Default value 0 Not inverted.

OV10	USER, RO	S34178	DigitalOutputs
------	----------	--------	----------------

Function This variable contains the value of the output status of the various functions that may be selected with OP14.

Valid values 0 and 1.

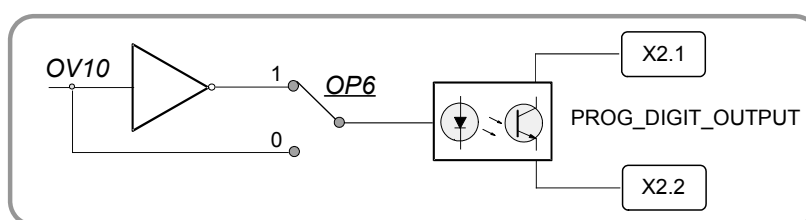

P. Position loop

PP217	FAGOR, RW	S00348	AccelerationFeedForwardPercentage
-------	-----------	--------	-----------------------------------

Function It sets the how much acceleration feed-forward is applied in position control and in velocity control. It is similar to parameter ACFGAIN <P26> of the axes of the 8055/55i CNC.

Valid values 0.0 ... 120.0 %.

Default value 0.0 %. The feed-forward effect is not applied.

PV51	FAGOR, RO	S00051	PositionFeedback1
------	-----------	--------	-------------------

Function Counter of the motor feedback pulses in 24.8 format that helps the CNC control the position feedback.

Valid values - 2 147 483 647 ... 2 147 483 647.

PV173	FAGOR, RO	S00173	MarkerPositionA
-------	-----------	--------	-----------------

Function Zero coordinate "latched" (captured and maintained) by the drive.

PC146	FAGOR, RW	S00146	NCControlledHoming
-------	-----------	--------	--------------------

Function Zero position latching command.

Q. Communication

QP1	FAGOR, RW	S00001	ControlUnitCycleTime
-----	-----------	--------	----------------------

Function Read parameter that indicates every how long the drives close the loop. Therefore, it defines the loop time.

NOTE. Any modification of this parameter becomes effective after RESETTING the unit.

Valid values 0 ... 10 000 μ s.

Default value 4000 μ s.

QP11	FAGOR, RW	S34768	CanBusSpeed
------	-----------	--------	-------------

Function It sets the transmission speed through the CAN bus. The CNC has a similar parameter. Both speeds must be the same in order to establish communication.

NOTE. Any modification of this parameter becomes effective after RESETTING the unit.

Valid values

0	1 MBd	4	125 kBd	8	10 kBd
1	800 kBd	5	100 kBd	others	1 MBd
2	500 kBd	6	50 kBd		
3	250 kBd	7	20 kBd		

Default value 0 → transmission speed = 1MBd.

QP17	BASIC, RW	S34788	CanOpenBorder
------	-----------	--------	---------------

Function Parameter that contains a numerical data in 16-bit binary code that may be used to activate or deactivate, bit by bit, the different specific controls implemented in the unit to work with the FAGOR CNC.

QP17= 0	ACTIVATE the control with FAGOR CNCs
QP17= 1	DEACTIVATE the control with FAGOR CNCs

Bit Nr	Meaning
15...7	Reserved
6	Position latch, cyclic, thorough and anticipated to the SYNC message.
5	The drive can only be enabled if it is in running (operative) state.
4	Internal interpolation between velocity commands.
3	Special behavior in case of errors.
2	Thorough control of the jitter of the SYNC message.
1	Thorough control of the arrival of the SYNC message.
0	Control of the ·toggle· bit of the control word DV32.

Default value

With FAGOR CNC as master device	Set all the bits to 0.
With another master device	It is recommended to set all the bits to 1, except bit 5 to 0.

QV22	FAGOR, RO	S00022	IDNListOfInvalidOperationDataForCP3
------	-----------	--------	-------------------------------------

Function Variable containing the parameters that are readjusted by the drive when it issues an “error E.502: incompatible parameters”. The parameters are listed by their bus identifier.

Valid values Any parameter bus identifier.

QV30	FAGOR, RO	S33495	FiberDistErrCounter
------	-----------	--------	---------------------

Function This variable may be used to diagnose CAN problems. It is an error counter that indicates the number of times a distortion error has occurred in the CAN communication.

Valid values 0 ... 65 535.

QV96	*BASIC, RO	S00096	SlaveArrangement
------	------------	--------	------------------

Función This variable indicates the node number assigned to the drive.

Valid values 1 ... 127.

QV190	FAGOR, RO	S34779	CanBusSyncJitter
-------	-----------	--------	------------------

Function This variable may be used to diagnose CAN problems. It reflects the oscillation of the synchronism messages with respect to the internal time base (clock) of the drive (in clock tick, 25 ns).

Valid values - 1 000 ... 1 000.

R. Rotor sensor

RP1	FAGOR, RW	S34268	FeedbackSineGain
-----	-----------	--------	------------------

RP2	FAGOR, RW	S34269	FeedbackCosineGain
-----	-----------	--------	--------------------

Function Compensation (proportional gain mode) of the amplitude of the sine/cosine signal that goes from the motor feedback to the drive. Entering 4 096 is the same as multiplying by 1. To assign a gain of 1.5 to the sine signal, set RP1 to 6 144 (= 4 096 x 1.5).

Valid values 0 → 0 % ... 8 192 → 200 %.

Default value 4 096 → 100 %.

RP3	FAGOR, RW	S34270	FeedbackSineOffset
-----	-----------	--------	--------------------

RP4	FAGOR, RW	S34271	FeedbackCosineOffset
-----	-----------	--------	----------------------

Function Compensation (offset mode) of the sine/cosine signal that goes from the motor feedback to the drive.

Valid values - 2 000 ... 2 000.

Default value 0.

RP20	USER, RW	S34305	StegmanABLevelSense
------	----------	--------	---------------------

Function Motor feedback failure protection sensitivity adjustment. See E.605.

Valid values 30 ... 100 %.

Default value 100 %.

RP77	FAGOR, RW	S00277	PositionFeedback1Type
------	-----------	--------	-----------------------

Function Type of encoder installed on the motor.

Valid values - 32 768 ... 32 767.

Default value 0.

RV1	USER, RO	S34274	FeedbackSine
-----	----------	--------	--------------

RV2	USER, RO	S34275	FeedbackCosine
-----	----------	--------	----------------

Function Sine and cosine of the feedback that goes from the motor to the drive as internal system variables.

Valid values - 512 ... 511.

RV3	FAGOR, RO	S34276	FeedbackRhoCorrection
-----	-----------	--------	-----------------------

Function Corrects the phase shift between the encoder shaft and the motor shaft. The motors are factory set and the value of this variable is stored in the encoder memory.

Valid values 0 ... 6 553.

RC1	*FAGOR, RW	S34281	EncoderParameterStoreCommand
-----	------------	--------	------------------------------

Function Command that could be used to store the content of MP1 and RV3 in the E²PROM of the SinCos or SinCoder encoder.

S. Speed

SP1	BASIC, RW	S00100	VelocityProportionalGain
-----	-----------	--------	--------------------------

SP2	BASIC, RW	S00101	VelocityIntegralTime
-----	-----------	--------	----------------------

Function Value of the proportional/integral action of the velocity PI.

Valid values SP1: 0.0 ... 999.9 mArms/(rpm).

SP2: 0.1... 999.9 ms.

Default value

Depends on the motor-drive combination.

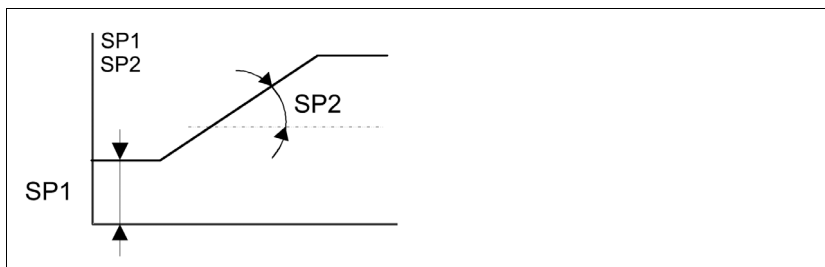

SP10	BASIC, RW	S00091	VelocityLimit
------	-----------	--------	---------------

Function

Maximum velocity limit for SV7 (VelocityCommandFinal).

Valid values

0 ... 110 % of the motor rated speed in rpm.

Default value

1 000 rpm.

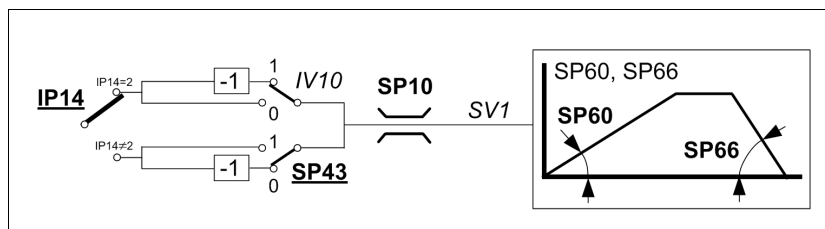

SP42	USER, RW	S00124	StandStillWindow
------	----------	--------	------------------

Function

Determines the value of the velocity window around zero that will be considered to be zero speed.

Valid values

0 ... motor rated speed in rpm.

Default value

20 rpm.

SP43	BASIC, RW	S00043	VelocityPolarityParameters
------	-----------	--------	----------------------------

Function

This parameter is used to change the sign of the velocity command in specific applications. It cannot be used to solve a positive feedback problem (axis runaway).

Valid values

0/1 Not inverted/inverted.

Default value

0 Not inverted.

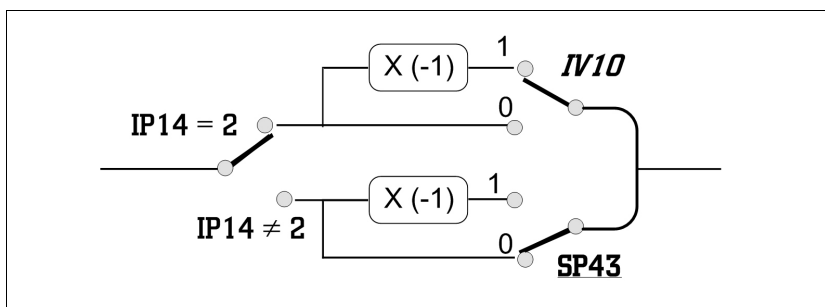

SP50	BASIC, RW	S34782	VelocityFeedbackFilterFrequency
------	-----------	--------	---------------------------------

Function Cutoff frequency of the first-order low-pass filter after the velocity feedback.

Valid values 0 (the filter is not applied) ... 4 000 Hz.

Default value 800 Hz.

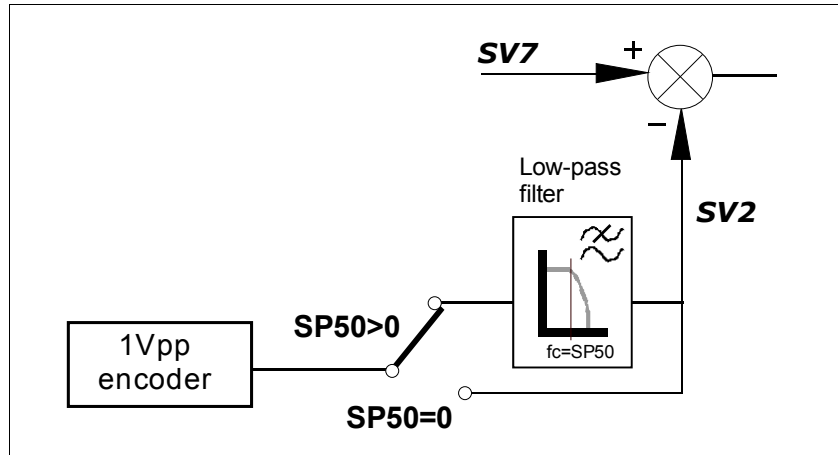

SP60	BASIC, RW	S00138	AccelerationLimit
------	-----------	--------	-------------------

Function Determines the value of the acceleration ramp applied to the velocity command. Setting it with a zero value means that no ramps will be applied.

Valid values 0.0 ... 400.0 rpm/ms.

Default value 0.0 rpm/ms.

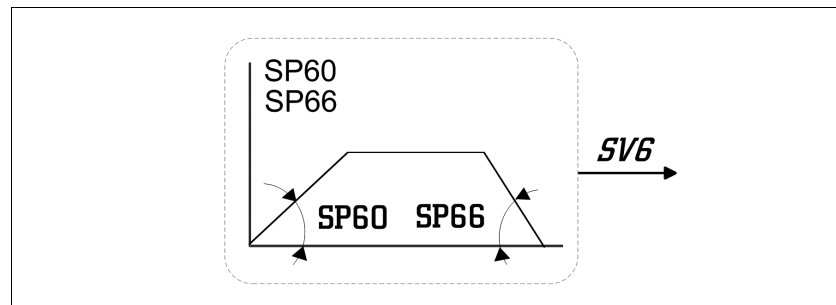

SP65	BASIC, RW	S34377	EmergencyAcceleration
------	-----------	--------	-----------------------

Function In emergency stop. If the bus voltage drops or there is a power outage for the unit in the acceleration, deceleration or constant power mode, The drive will always issue an E.003 or E.307 error and will enter into a dynamic braking sequence without warning the CNC (DV32.13=0) or sending the warning "WarningMainsLine" (DV31.10) to the CNC two seconds before (DV32.13=1). It stops with the emergency ramp until its speed is zero as long as the mechanical energy stored in the motor allows it. Therefore, it limits the command acceleration for stopping the motor.

If anytime during the sequence, the Drive Enable is interrupted, the motor will turn by inertia.

SP65=0 cancels this limiting effect.

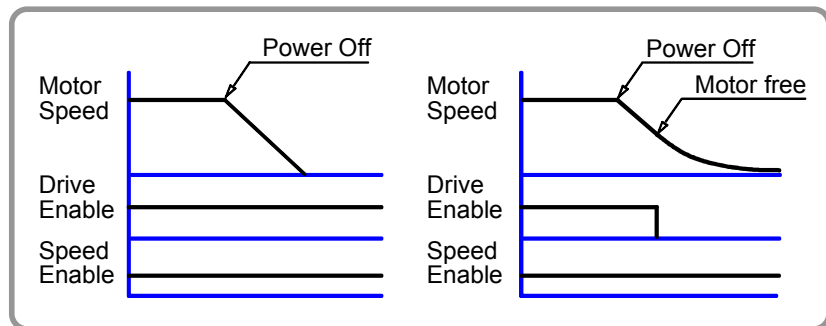

Valid values 0.0 (by default), ..., 400.0 rpm/ms.

SP66	BASIC, RW	S34386	VelocityDecelerationTime
------	-----------	--------	--------------------------

Function Determines the value of the deceleration ramp applied to the velocity command. Setting it with a zero value means that no ramps will be applied.

Valid values 0.0 (by default), ..., 400.0 rpm/ms.

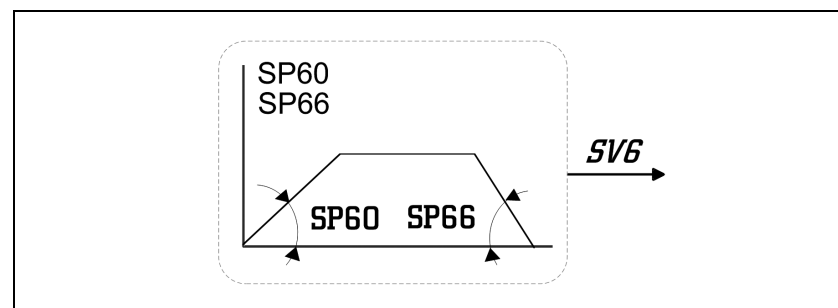

SV1	BASIC, RW	S00036	VelocityCommand
-----	-----------	--------	-----------------

Function Velocity command after the SP45 selector.

Valid values - 6 000.0000 ... 6 000.0000 rpm.

SV2	BASIC, RO	S00040	VelocityFeedback
-----	-----------	--------	------------------

Function Velocity feedback.

Valid values - 6 000.0000 ... 6 000.0000 rpm.

SV6	BASIC, RO	S34390	VelocityCommandAfterFilters
-----	-----------	--------	-----------------------------

Function Velocity command after applying limits, ramps, etc.

Valid values - 6 000.0000 ... 6 000.0000 rpm.

SV7	BASIC, RO	S34380	VelocityCommandFinal
-----	-----------	--------	----------------------

Function Final velocity command applied to the loop.

Valid values - 6 000.0000 ... 6 000.0000 rpm.

T. Torque and power

TP10	USER, RW	S34670	ConstantPositiveTorqueCompensation
------	----------	--------	------------------------------------

Function Constant friction compensation in the positive direction of the velocity. It is a constant value for all the positive reference speeds. See the figures later on.

Valid values 0.0 (by default), ..., 100.0 N·m.

TP11	USER, RW	S34671	ConstantNegativeTorqueCompensation
------	----------	--------	------------------------------------

Function Constant friction compensation in the negative direction of the velocity. It is a constant value for all the negative reference speeds. See the figure further below.

Valid values 0.0 (by default), ..., 100.0 N·m.

TP12	USER, RW	S34672	DynamicPositiveTorqueCompensation
------	----------	--------	-----------------------------------

Function Dynamic friction compensation in the positive direction of the velocity. It is the value of the compensation with the reference speed equal to SP10. It is directly proportional to other positive reference speeds. See the figure further below.

Valid values 0.0 (by default), ..., 100.0 N·m.

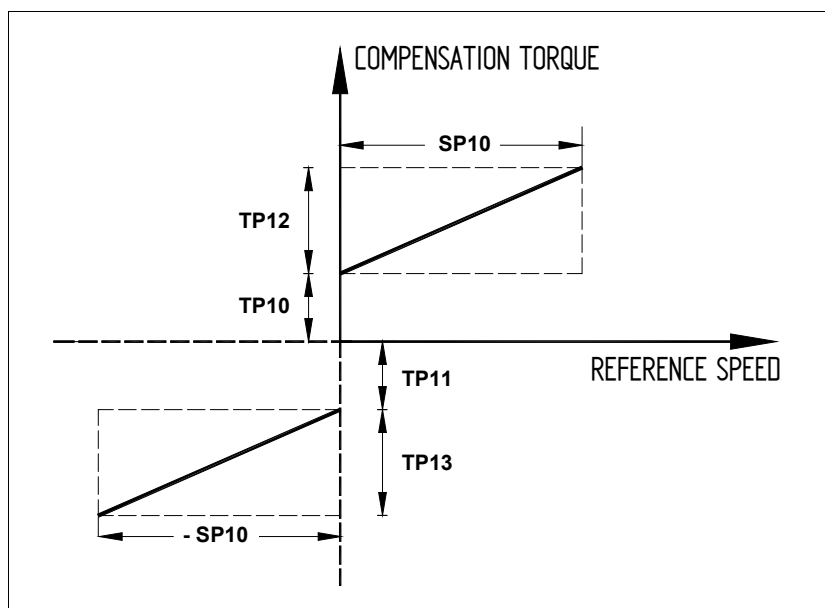

TP13	USER, RW	S34673	DynamicNegativeTorqueCompensation
------	----------	--------	-----------------------------------

Function Dynamic friction compensation in the negative direction of the velocity. It is the value of the compensation with the reference speed equal to - SP10. It is directly proportional to other negative reference speeds. It is set as an absolute value, i.e. in positive, although the compensation has a negative value. See the figure further up.

Valid values 0.0 (by default), ..., 100.0 N·m.

TP14	USER, RW	S34676	TorqueCompensationTimeConstant
------	----------	--------	--------------------------------

Function

Time constant of the torque compensation. Before applying it, it is filtered with a low-pass filter to improve the friction behavior in velocity direction changes.

The constant friction suddenly changes when changing the sign of the reference speed. The filters “smooths” the compensation torque preventing jerks in the system when reversing the moving direction and better modeling the behavior of friction.

NOTE. With TP14=0, all the friction compensations are canceled.

Valid values

0.0 (by default), ..., 2 000.0 ms.

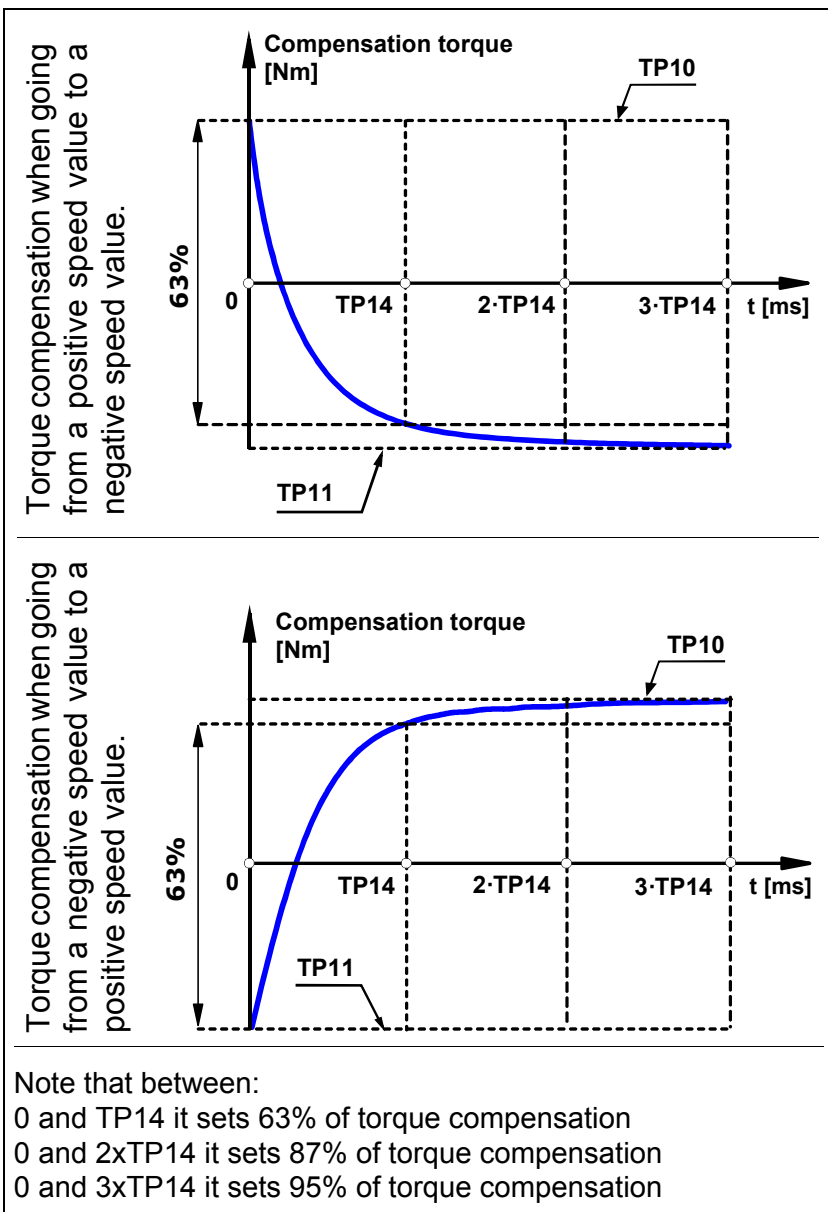

TP15	USER, RW	S34677	TorqueCompensationSpeedHysteresis
------	----------	--------	-----------------------------------

Function Amplitude of the hysteresis in friction torque compensation.

NOTE. With TP15=0, the drive internally sets a fixed Hysteresis amplitude of about SP10 rpm /10 000 to compensate the friction torque. Remember that SP10 is the maximum speed of the application; therefore, it will be set to at least 0.2000 rpm which corresponds to a motor of 2 000 rpm.

Valid values 0.2000 ... 1 000.0000 rpm.

Default value 0.0000 rpm.

TV1	USER, RO	S00080	TorqueCommand
-----	----------	--------	---------------

TV2	USER, RO	S00084	TorqueFeedback
-----	----------	--------	----------------

Function Displays the values of the command and torque feedback.

Valid values - 99.9 ... 99.9 N·m.

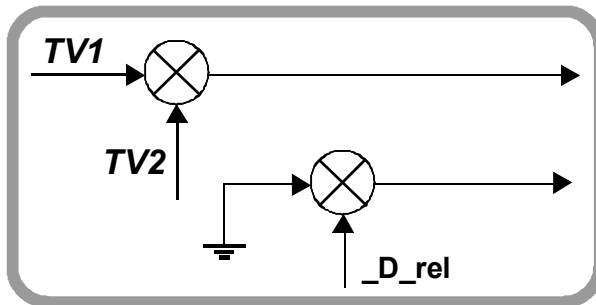

TV4	USER, RO	S34380	SpeedIntegralAction
-----	----------	--------	---------------------

Function Output of the velocity PI integrator. When the acceleration is not extremely high, it is the same as the friction torque. When compensating for friction, the value of this variable must be reduced to near zero.

Valid values - 1 000.0 ... 1 000.0 N·m.

ERROR CODES

E.001 Internal

Contact Fagor Automation.

E.003 With torque, there is a drop at the power bus

Probably one of the three-phase lines has dropped or a drive has failed. Verify that the lines and the drives are in good condition and restart the system.

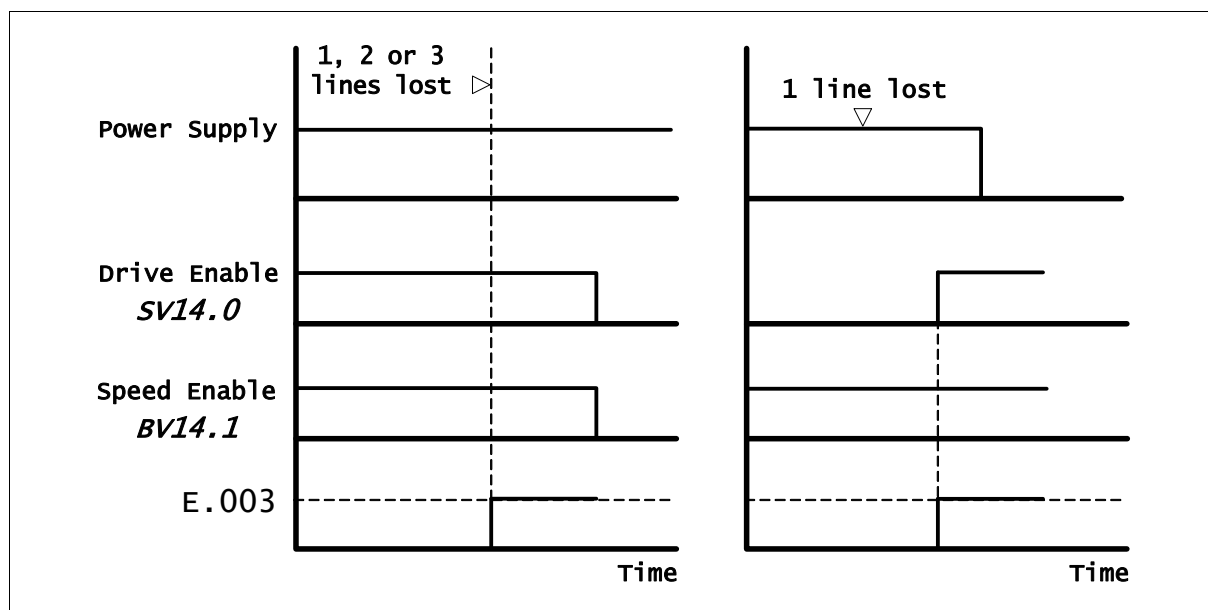

E.004 Emergency stop exceeding time limit GP3

An attempt has been made to stop the motor by canceling **Speed Enable**. The system has tried to stop the motor at full torque, but it has not been able to stop it in the time frame set by parameter GP3 (**StoppingTimeout** = maximum time allowed for braking, before considering the error for being unable to stop it in the set time) or the parameter that determines when the motor is considered to be stopped (SP42) **Minimum velocity threshold**, is too small. Bear in mind that zero speed (total lack of velocity) does not exist, there is always a minimum amount of speed noise due to feedback.

Solutions

The load that must stop the motor is too large to stop it in the time frame set by GP3 and the value given to this parameter must be increased.

The threshold or velocity window considered zero (SP42) is too small; hence, increase the value of this parameter.

The module is performing poorly and is unable to stop the motor. The module may be defective.

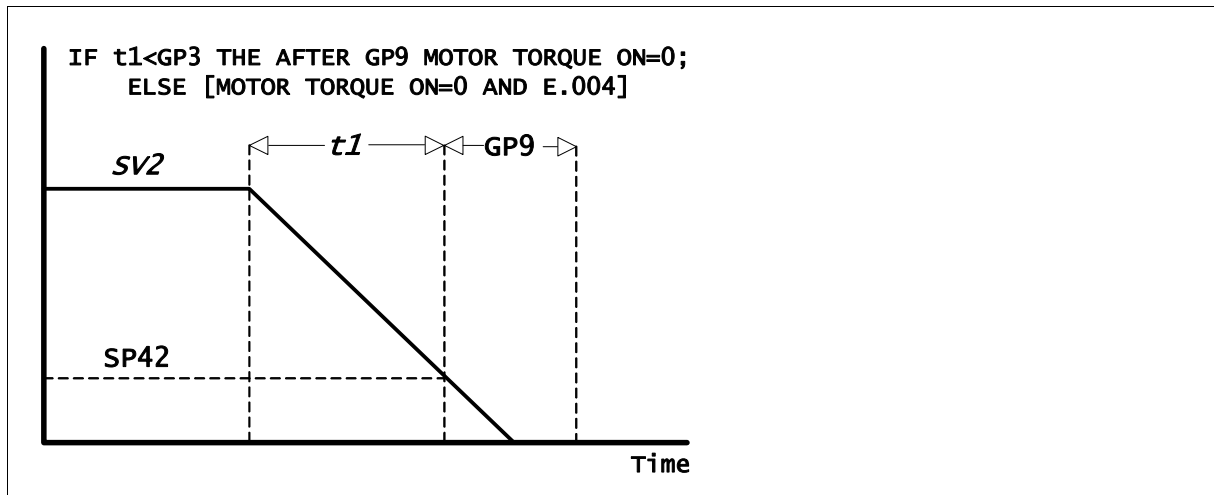

E.106 Extreme temperature at the heatsink (of the IGBT's) E.106

The drive is carrying out a task that overheats the power devices. Stop the system for several minutes and decrease the effort demanded from the drive.

E.108 Motor overheated E.108

The motor has overheated. The motor temperature measuring cables (position sensor cable) or the temperature sensor itself are defective. The application may be demanding high current peaks. Stop the system for several minutes and decrease the effort demanded from the drive. Cool the motor.

E.200 Overspeed E.200

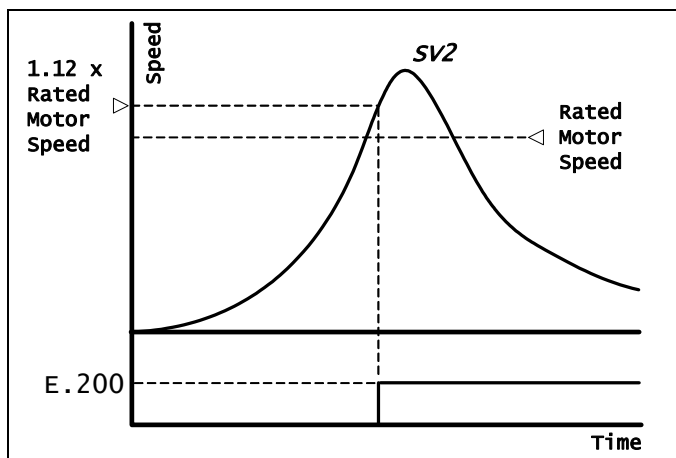

The motor speed has exceeded the value of SP10 in a 12%.
Bad cabling of the position sensor or of the motor power.
The velocity loop is adjusted wrong.
Decrease the speed overshoot in the system response.

E.201 Motor overload E.201

E.202 Drive overload E.202

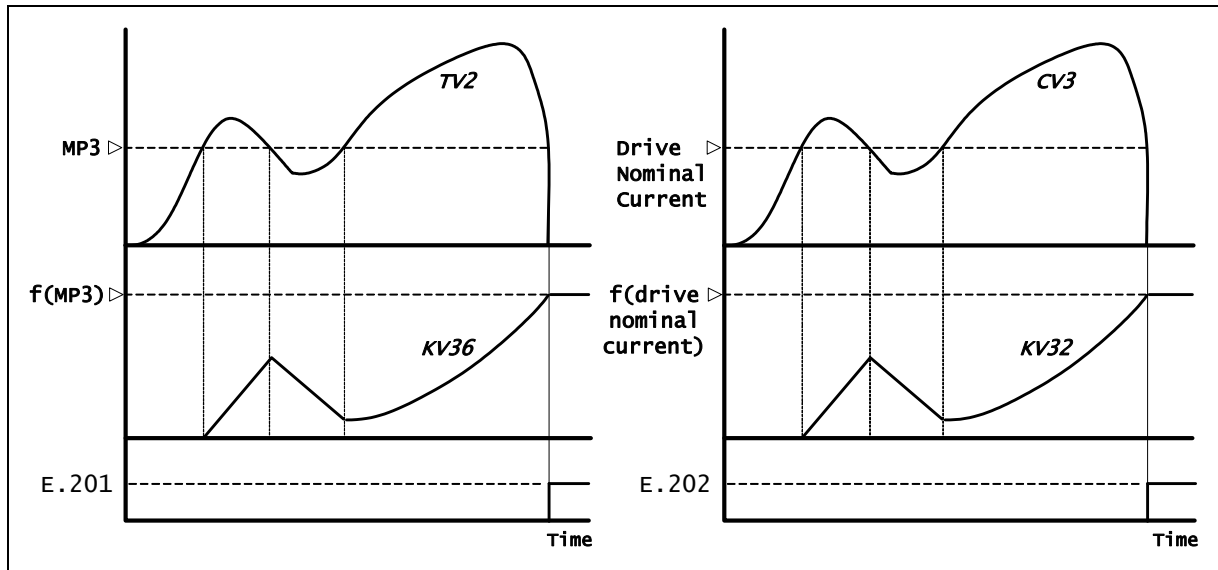

The I²t protection of the drive went off. The duty cycle is greater than the system can provide. Decrease the speed overshoot in the system response.

E.214 Short-circuit

E214

There is short-circuit at the drive module. Reset the error. If it persists, may be because:

- An erroneous sequence when connecting the power cables or a short-circuit between them.
- The parameters may be wrong or there is a fault at the drive.

Contact Fagor Automation.

After displaying E.214, one of the codes of the following table will be displayed.

The drive where the alarm has been detected is:

1L	The 1st one of the bottom	3L	The 3rd one of the bottom
1H	The 1st one of the top	3H	The 3rd one of the top
2L	The 2nd one of the bottom	CR	That of the Ballast
2H	The 2nd one of the top		

E.304 Power bus voltage of the drive too high

E304

The hardware of the drive module detects that the voltage at the power bus is too high. When using an external Ballast, it is not connected properly. The Ballast resistor is burned.

Disconnect the power supply and check the proper connection of the Ballast circuit.

E.307 Power bus voltage too low

E307

The mains voltage is too low.

Disconnect the power supply and check the proper condition of the lines.

E.314 Ballast circuit overload**E.314**

Due to the duty cycle, the Ballast resistor is overloaded.

Resize the Ballast resistor.

Decrease the duty cycle.

Smooth the duty cycle by applying acceleration ramps.

E.403 Synchronism message missing**E.403**

The synchronism message is received erroneously during two consecutive cycles or is no longer received. If the error comes up only once, it adds 1 unit to the value of the QV30 variable (distortion on the line).

E.412 Synchronism message oscillation**E.412**

The synchronism message must be received within a $\pm 10 \mu\text{s}$ margin of the cycle time indicated in parameter QP1, when starting up the unit.

This time margin is usually 4 ms. Therefore, if this is received out of this margin twice in a row, the drive warns about this error. If it only occurs one, it adds 1 unit to the value of the QV30 variable.

E.413 Wrong handshake**E.413**

The handshake bit, included in the master's control word and in the drive's status word, does not follow the indicated sequence.

E.502 Incompatible parameters**E.502**

Parameter incompatibility.

Example

Let us assume a drive that controls a 4000 rpm motor with its parameters set (e.g.: speed limit SP10 = 4400). If now, a 2000 rpm motor is connected, the speed limit will be beyond the value allowed for this new motor. The RAM memory will then be readjusted and error E.502 will be issued indicating the wrong parameters in the QV22 variable. If the unit is reset without having saved the parameters, the error will come up again. The error will disappear when the parameters (readjusted in RAM memory by the drive) are saved into E²PROM memory using the GC1 command.

E.506 Motor table missing**E.506**

Contact Fagor Automation.

E.510 Incoherent combination of motor and feedback**E.510**

Motor not accepted by the drive.

Motor's power voltage is different from that of the drive (e.g.: motor FXM34.40A.E1.000 with MCP-20L drive).

E.605 Excessive damping of the analog signals of the motor feedback.**E.605**

Some of the sine or cosine signals of the encoder has reached a peak level lower than 150 mV.

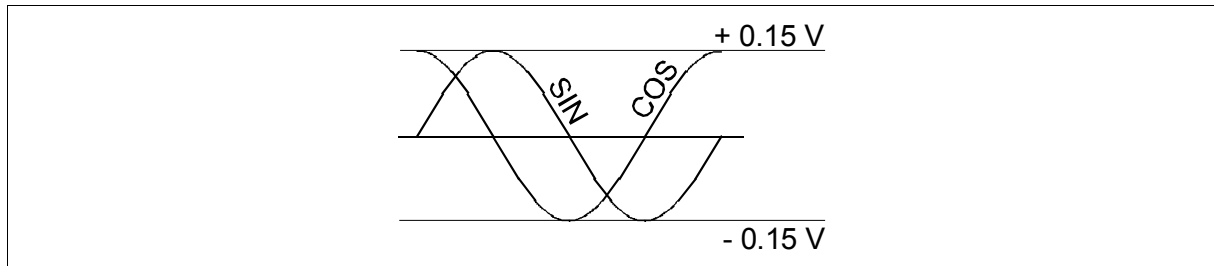

Contact Fagor Automation.

E.801 Encoder not detected**E.801**

The drive has not detected the rotor sensor.

Match the selected sensor with the feedback installed.

Contact Fagor Automation.

E.802 Defective encoder**E.802**

Communication error when using a SinCos or SinCoder encoder.

Incoherent U, V, W signals when using an incremental I0 encoder.

Contact Fagor Automation.

E.803 Encoder not initialized**E.803**

Contact Fagor Automation.

PARAMETERS, VARIABLES & COMMANDS. IDs

Mnem.	Name	Level	IDSER	Ac	Min.	Max.	Def.	Units	Pag.
BV14	NotProgrammableIOs	Fagor	32972	RO	0	65535	-	-	51
CP1	CurrentProportionalGain	Fagor	00106	RW	0	999	-	-	51
CP2	CurrentIntegralTime	Fagor	00107	RW	0	999	-	-	51
CP20	CurrentLimit	Basic	33075	RW	0.00	50.00	0.00	A	51
CP30	CurrentCommandFilter1Type	Fagor	33076	RW	0	1	0	-	52
CP31	CurrentCommandFilter1Frequency	Fagor	33080	RW	0	4000	0	Hz	52
CP32	CurrentCommandFilter1Damping	Fagor	33081	RW	0	1000	0	Hz	52
CV1	Current1Feedback	User	33077	RO	-50.00	50.00	-	A	52
CV2	Current2Feedback	User	33078	RO	-50.00	50.00	-	A	52
CV3	CurrentFeedback	User	33079	RO	-50.00	50.00	-	A	53
CV10	Current1Offset	Fagor	33073	RO	-2.000	2.000	-	A	53
CV11	Current2Offset	Fagor	33074	RO	-2.000	2.000	-	A	53
DC1	ResetClass1Diagnostics	User	00099	RW	0	15	0	-	54
DC2	ClearHistoricOfErrorsCommand	User	33170	RW	0	15	0	-	54
DV17	HistoricOfErrors	User	33178	RO	-	-	-	-	53
DV31	DriverStatusWord	Fagor	00135	RO	0	65535	-	-	53
DV32	MasterControlWord	Fagor	00134	RW	0	65535	0	-	54
GC1	BackupWorkingMemoryCommand	Basic	00264	RW	0	15	0	-	56
GC3	SincoderAutoTunningCommand	Fagor	33498	RW	0	15	0	-	56
GC10	LoadDefaultsCommand	Basic	00262	RW	0	15	0	-	57
GP3	StoppingTimeout	Basic	33470	RW	0	9999	500	ms	55
GP5	ParameterVersion	Basic	33472	RO	-	-	-	-	55
GP9	DriveOffDelayTime	Basic	00207	RW	0	9999	50	ms	55
GP15	AutomaticInitialization	Fagor	33493	RW	0	1	1	-	55
GP16	MonoPhaseSelector	Basic	33495	RW	0	1	0	-	55
GV2	ManufacturerVersion	Basic	00030	RO	-	-	-	-	56
GV5	CodeChecksum	Basic	33474	RO	-	-	-	-	56
GV7	Password	Basic	00267	RW	0	9999	0	-	56
GV9	DriveType	Basic	00140	RO	-	-	-	-	56
GV11	SoftReset	Basic	33476	RW	0	16	0	-	56
GV16	MotorTableVersion	Basic	33484	RO	-	-	-	-	56
GV75	ErrorList	Fagor	00375	RO	-	-	-	-	56
HV5	PLDVersion	Basic	33063	RO	-	-	-	-	57
IP6	DigitalInputPolarity	User	33678	RW	0	1	0	-	57
IV10	DigitalInputs	User	33675	RO	0	1	-	-	57
KP3	ExtBallastPower	User	33882	RW	200	2000	200	W	58
KP4	ExtBallastEnergyPulse	User	33884	RW	200	2000	200	J	58
KV6	MotorTemperature	Basic	00383	RO	0	200	-	° C	58
KV10	CoolingTemperature	User	33870	RO	0	200	-	° C	58
KV32	I2tDrive	User	33877	RO	0	100	-	%	58
KV36	I2tMotor	User	33879	RO	0	100	-	%	58
KV40	I2tCrowbar	User	33883	RO	0	100	-	%	58
KV41	BallastSelect	User	33885	RW	0	1	1	-	58
MP1	MotorType	Basic	00141	RW	-	-	-	-	59
MP2	MotorTorqueConstant	Fagor	33968	RW	0.00	10.00	10.00	N·m/A	59
MP3	MotorContinuousStallCurrent	Fagor	00111	RW	0.00	50.00	10.00	A	59
MP24	MotorMomentumOfInertia	Fagor	33988	RW	0.1	1000.0	-	kg·cm ²	59
NP1	LoadMomentumOfInertiaPercentage	User	34968	RW	0.00	1000.00	0.00	%	60
NP116	ResolutionOfFeedback1	Fagor	00116	RO	0	65535	-	pulses	60
NP121	InputRevolutions	Fagor	00121	RW	1	65535	1	rev	60
NP122	OutputRevolutions	Fagor	00122	RW	1	65535	1	rev	60

Mnem.	Name	Level	IDSER	Ac	Min.	Max.	Def.	Units	Pag.
NP123	FeedConstant	Fagor	00123	RW	0	2 ³¹ -1	50000	mm	60
OP6	DigitalOutputPolarity	User	34184	RW	0	1	0	-	61
OV10	DigitalOutputs	User	34178	RO	0	1	0	-	61
PC146	NCControlledHoming	Fagor	00146	RW	0	15	0	-	61
PP217	AccelerationFeedforwardPercentage	Fagor	00348	RW	0.0	120.0	0.0	%	61
PV51	PositionFeedback1	Fagor	00051	RO	- 2 ³¹	2 ³¹ -1	-	pulses	61
PV173	MarkerPositionA	Fagor	00173	RO	- 2 ³¹	2 ³¹ -1	-	-	61
QP1	ControlUnitCycleTime	Fagor	00001	RW	0	10000	4000	-	62
QP11	CanBusSpeed	Fagor	34768	RW	0	20	0	-	62
QP17	CanOpenBorder	Basic	34788	RW	-	-	-	-	62
QV22	IDNListOfInvalidOperationData	Fagor	00022	RO	-	-	-	-	63
QV30	FiberDistErrCounter	Fagor	33495	RO	0	65535	0	-	63
QV96	SlaveArrangement	Basic	00096	RO	1	127	-	-	63
QV190	CanBusSyncJitter	Fagor	34779	RO	- 1000	1000	0	Tick (25 ns)	63
RC1	EncoderParameterStoreCommand	Fagor	34281	RW	0	15	0	-	64
RP1	FeedbackSineGain	Fagor	34268	RW	0	8192	4096	-	63
RP2	FeedbackCosineGain	Fagor	34269	RW	0	8192	4096	-	63
RP3	FeedbackSineOffset	Fagor	34270	RW	- 2000	2000	0	-	64
RP4	FeedbackCosineOffset	Fagor	34271	RW	- 2000	2000	0	-	64
RP20	StegmanABLevelSense	User	34305	RW	30	100	100	%	64
RP77	PositionFeedback1Type	Fagor	00277	RW	- 32768	32767	0	-	64
RV1	FeedbackSine	User	34274	RO	- 512	511	-	-	64
RV2	FeedbackCosine	User	34275	RO	- 512	511	-	-	64
RV3	FeedbackRhoCorrection	Fagor	34276	RO	0	65535	-	-	64
SP1	VelocityProportionalGain	Basic	00100	RW	0.0	999.9	-	mA/rpm	64
SP2	VelocityIntegralTime	Basic	00101	RW	0.1	999.9	-	ms	64
SP10	VelocityLimit	Basic	00091	RW	0	9999	1000	rpm	65
SP42	StandStillWindow	User	00124	RW	0	9999	20	rpm	65
SP43	VelocityPolarityParameters	Basic	00043	RW	0	1	0	-	65
SP50	VelocityFeedbackFilterFrequency	Basic	34782	RW	0	4000	800	Hz	66
SP60	AccelerationLimit	Basic	00138	RW	0.0	400.0	0.0	rpm/ms	66
SP65	EmergencyAcceleration	Basic	34377	RW	0.0	400.0	0.0	rpm/ms	66
SP66	VelocityDecelerationTime	Basic	34386	RW	0.0	400.0	0.0	rpm/ms	67
SV1	VelocityCommand	Basic	00036	RW	- 6000.0000	6000.0000	-	rpm	67
SV2	VelocityFeedback	Basic	00040	RO	- 6000.0000	6000.0000	-	rpm	67
SV6	VelocityCommandAfterFilters	Basic	34390	RO	- 6000.0000	6000.0000	-	rpm	67
SV7	VelocityCommandFinal	Basic	34380	RO	- 6000.0000	6000.0000	-	rpm	67
TP10	ConstantPositiveTorqueCompensation	User	34670	RW	0.0	100.0	0.0	N·m	68
TP11	ConstantNegativeTorqueCompensation	User	34671	RW	0.0	100.0	0.0	N·m	68
TP12	DynamicPositiveTorqueCompensation	User	34672	RW	0.0	100.0	0.0	N·m	68
TP13	DynamicNegativeTorqueCompensation	User	34673	RW	0.0	100.0	0.0	N·m	68
TP14	TorqueCompensationTimeConstant	User	34676	RW	0.0	2000.0	0.0	ms	69
TP15	TorqueCompensationSpeedHysteresis	User	34677	RW	0.2000	1000.0000	0.0000	rpm	70
TV1	TorqueCommand	User	00080	RO	- 99.9	99.9	-	N·m	70
TV2	TorqueFeedback	User	00084	RO	- 99.9	99.9	-	N·m	70
TV4	SpeedIntegralAction	User	34680	RO	- 1000.0	1000.0	-	N·m	70

User notes

User notes



FAGOR AUTOMATION

Fagor Automation S. Coop.

B.º San Andrés, 19 - Apdo. 144

E-20500 Arrasate-Mondragón,

Gipuzkoa ·Spain·

Tel: +34 943 719 200

+34 943 039 800

Fax: +34 943 791 712

E-mail: info@fagorautomation.es

www.fagorautomation.com



VELOCITY CONTROL BLOCK DIAGRAM

GENERAL PARAMETERS	
GV2	Software version
GV7	Password
GC10	Default parameters
GV11	Soft Reset
GC1	Store parameters
GV9	Drive type
GV5	Code Checksum
GC3	Autophasing command

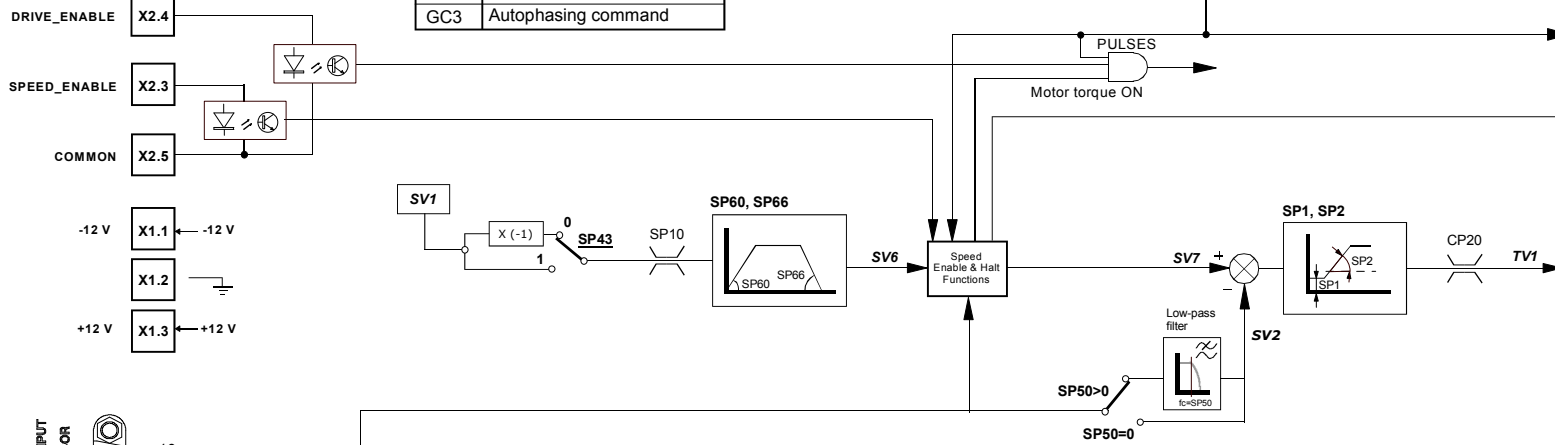

ERROR	DESCRIPTION
E.001	Watch dog
E.003	Power supply fault
E.004	Stop time > GP3
E.106	Drive overtemp
E.108	Motor overtemp
E.200	Overspeed
E.201	I2t motor
E.202	I2t drive
E.214	Short-circuit
E.304	Bus overvoltage
E.307	Bus low voltage
E.314	I2t Ballast
E.403	Synchronism message missing
E.412	Synchronism message oscillation
E.413	Wrong handshake
E.502	Incompatible parameters
E.506	Motor table missing
E.510	Incoherent combination of motor and feedback
E.605	Feedback signals excessively damped
E.801	Encoder not detected
E.802	Defective encoder
E.803	Encoder not initialized

MOTOR PARAMETERS	
MP1	Motor type
MP2	Torque constant
MP3	Rated current
MP24	Inertia

FXM - X	
FAGOR SYNCHRONOUS MOTOR	
SIZE	1, 3, 5, 7
LENGTH	1, 2, 3, 4, 5
RATED SPEED	12 1200 rev/min 30 3000 rev/min 20 2000 rev/min 40 4000 rev/min
WINDING	F 220 V AC A 400 V AC
FEEDBACK TYPE	I0 Incremental encoder (2500 ppt) A1 Absolute multi-turn SinCos encoder (1024 ppt) E1 SinCoder encoder (1024 ppt)
FLANGE & SHAFT	0 IEC Standard 1 Keyless shaft 8 NEMA Standard (USA) 9 Special
BRAKE OPTION	0 Without brake 1 With standard brake (24 V DC)
VENTILATION	0 Without fan 1 With standard fan 9 With special fan
SPECIAL CONFIGURATION	X
SPECIFICATION	01 → ZZ Only when it has a special configuration (X) !

FKM - K	
MOTOR SERIES	
SIZE	2, 4, 6
LENGTH	1, 2, 3, 4, 6
RATED SPEED	20 2000 rev/min 45 4500 rev/min 30 3000 rev/min 50 5000 rev/min 40 4000 rev/min 60 6000 rev/min
WINDING	A 400 V AC F 220 V AC
FEEDBACK TYPE	A3 Multi-turn absolute sinusoidal 1Vpp -1024 ppt- (taper shaft) E3 Sinusoidal 1Vpp encoder -1024 ppt- (taper shaft) I0 TTL incremental encoder -2500 ppt-
FLANGE AND SHAFT	0 With keyway (half-key balancing) 1 Cylindrical (with no keyway) 2 Shaft with keyway and seal 3 Keyless shaft with seal 9 Special configuration
BRAKE OPTION	0 Without brake 1 With standard brake - 24 V DC - 2 With extra brake - 24 V DC -
FAN AND INERTIA OPTION	0 Standard 1 Electro-ventilated 8 Low inertia 9 Low inertia and electro-ventilated (future)
WINDING OPTION	None Standard 2 Optimized for ACSD-16H 3 Small size
TEMPERATURE SENSOR	0/none PTC KT84 1 PTC PT1000 (future)
EXTRAS	- None K Special configuration U NRTL/SAFET certification (future)
SPECIFICATION	01 ... 99 Only when it has a special configuration "K"

Notes.
Encoders with reference:
I0, only available on FXM/FKM servomotors, "F" winding.
E1/A1/E3/A3, only available on FXM/FKM servomotors, "A" winding.

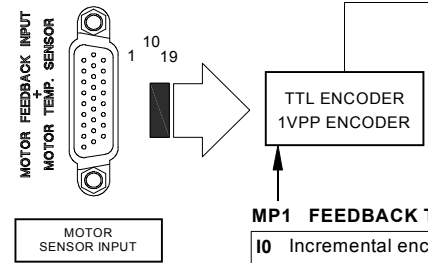

MP1 FEEDBACK TYPE

- I0 Incremental encoder ·2500 ppt·
- E1 SinCoder encoder ·1024 ppt·
- E3 SinCos encoder - taper shaft - ·1024 ppt·
- A1 Multi-turn abs. SinCos encoder (1024 ppt)
- A3 Multi-turn abs. SinCos encoder -taper shaft-· 1024 ppt·

ERROR FUNCTIONS

Function "E.003" Power Supply fault

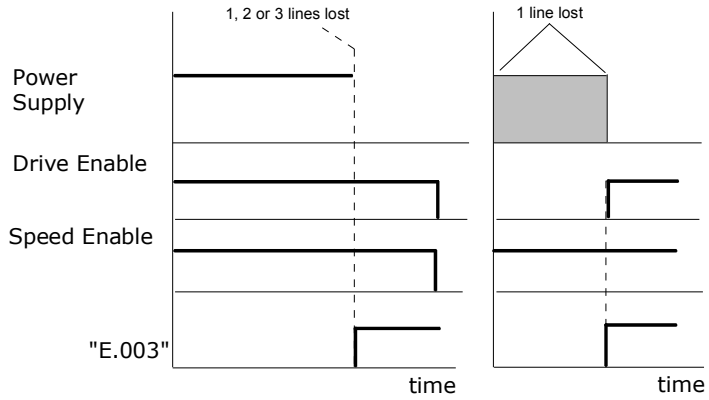

Function "E.106" Drive Overtemp

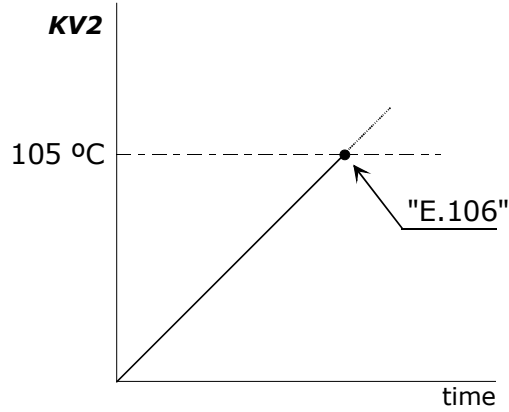

Function "E.200" Overspeed

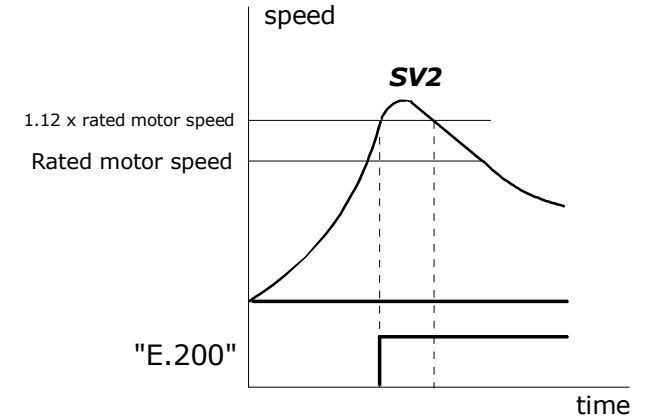

Function "E.201" Motor Overload

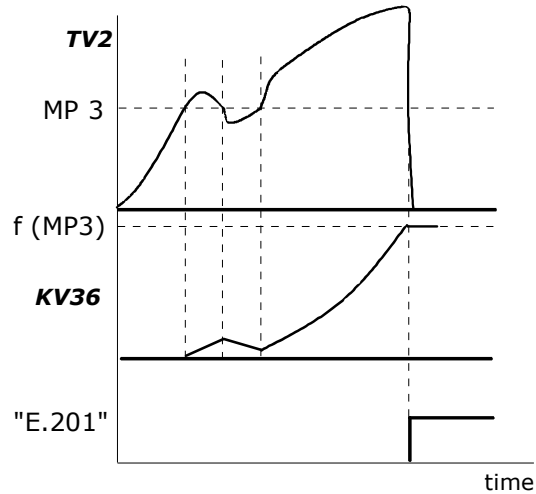

Function " E.202 " Drive Overload

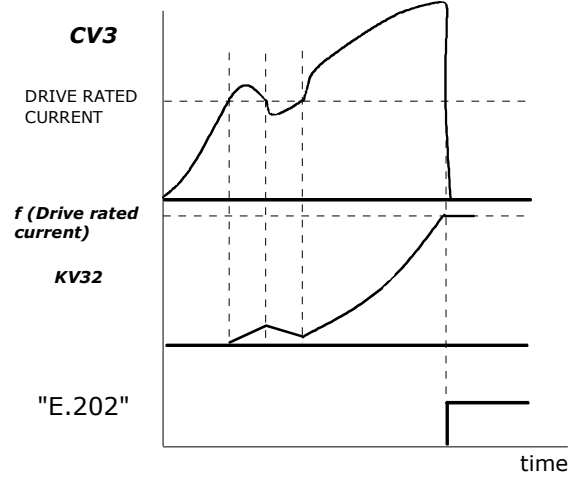

Function " E.314" Ballast Overload

